



SIL 407.01

NOVEMBER 25, 2008

Page 1 of 95

TO: LeTourneau Technologies Dealers and Users
FROM: LeTourneau Technologies Product Support
SUBJECT: Air System Update
MODELS: All 50 Series Loaders and Dozers

The purpose of this Service Information Letter is to advise dealers and users that field and factory testing has determined that the root cause of various air system problems, including short compressor life and system contamination, is high compressor duty cycle caused by major leaks in the air system – particularly in the KLENZ system.

The air system update will:

- Simplify the compressed air system
- Convert from Head Unloading to Discharge Line Unloading (DLU)
- Eliminate KLENZ system air leaks by performing regular maintenance
- Use LINCOS to monitor for massive air leaks that could cause the compressor to work over its limits.

NOTE

This update requires that the Bendix air dryer P/N 425-8485 and the Klenz tank P/N 408-1394 be installed. Required parts are listed in the Parts List in Section 3 if these units are not currently on the machine.

Process:

Order Parts: Refer Section 3 of this SIL.

Install Components per Section 4 of this SIL.

A revised machine configuration will be necessary to enable appropriate testing. The machine configuration will include proper monitoring of the updated components of the air system.

Submit supporting documentation of completion with Warranty Claim. Up to 40 hours of labor may be included. A claim process is necessary to recover the cost of parts, plus labor (up to 40 hours).

Blank on purpose for double sided printing

Loader / Dozer Air System Update



SUMMARY:

Testing in the field and at the factory has determined that the root cause of various air system problems including short compressor life and system contamination is high compressor duty cycle caused by major leaks in the air system – particularly in the KLENZ system.

SOLUTION:

- Simplify the compressed air system
- Convert from Head Unloading to Discharge Line Unloading DLU
- Eliminate KLENZ system air leaks by performing regular maintenance
- Use LINCOS to monitor for massive air leaks that could cause the compressor to work over its limits.

NOTE

The updates documented in the following pages are contingent on the air system having KLENZ set at minimum 60 second cycle time, a Bendix air dryer, a KLENZ air tank as pictured above. Contact your dealer and LTI Product Support if you have any variances from these items.

Section	Title	Page
1	Theory of Operation	3
2	Overview of Update Kit	15
3	Parts List for Update Kit	25
4	Detailed Installation Procedure for Update Kit	29
5	Installation Check List	67
6	Air System Maintenance	71
7	Air System Troubleshooting	77

Blank on purpose for double sided printing

Section1:

THEORY OF OPERATION

Blank on purpose for double sided printing

Theory of Operation

Air Compressor Duty Cycle:

The duty cycle of a compressor should be less than 25%. This means that if the compressor is on for 15 seconds building air pressure – then it should be off for at least 45 seconds to cool down. High duty cycle means that the air compressor is on for a higher percentage of time, runs hotter and contributes to shorter life.

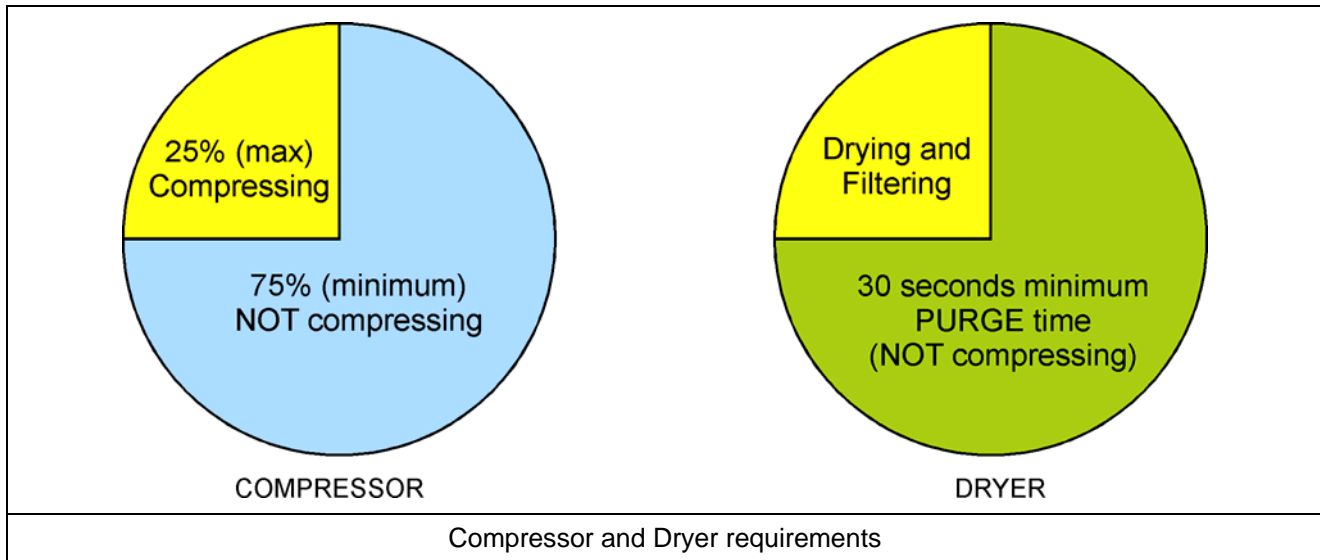

The compressor must be in an off state for more than 30 seconds to allow the air dryer to properly function.

The nominal pressure setting for a machine with large brake canisters is 135 psi. (The nominal air pressure for a machine with the small brake canisters is 120 psi). This document mainly describes the pressure changes in a system with the large brakes. The pressure changes in a similar manner on a machine with the small brakes – just at a lower pressure level.

The system air pressure will move back and forth between the pressure setting and about 20 psi lower. The compressor will come on when the pressure decreases to 115 psi and will turn off when the pressure reaches 135 psi. The 20 psi difference between high and low is called hysteresis and is a characteristic of the governor. If the hysteresis is larger than 20 psi the governor is defective and should be replaced.

The air compressor will be compressing for a short time to raise the pressure from 115 to 135 psi in a normal air system. It will stop compressing when the pressure reaches 135 psi. The system pressure will then slowly decrease depending on air usage by items such as the KLENZ system, air horn, air brakes, leaks, etc. The decrease time will be much longer than the compression time in a normally operating air system. The percentage of on time will typically be in the 5-15% range. The actual time compressing and not compressing will depend on air usage in the air system.

NOTE

The air compressor will provide the most air flow at lower air pressure settings. Raising the air pressure setting will reduce the airflow capability of the air compressor. The air pressure on the machines should be run at the recommended settings.

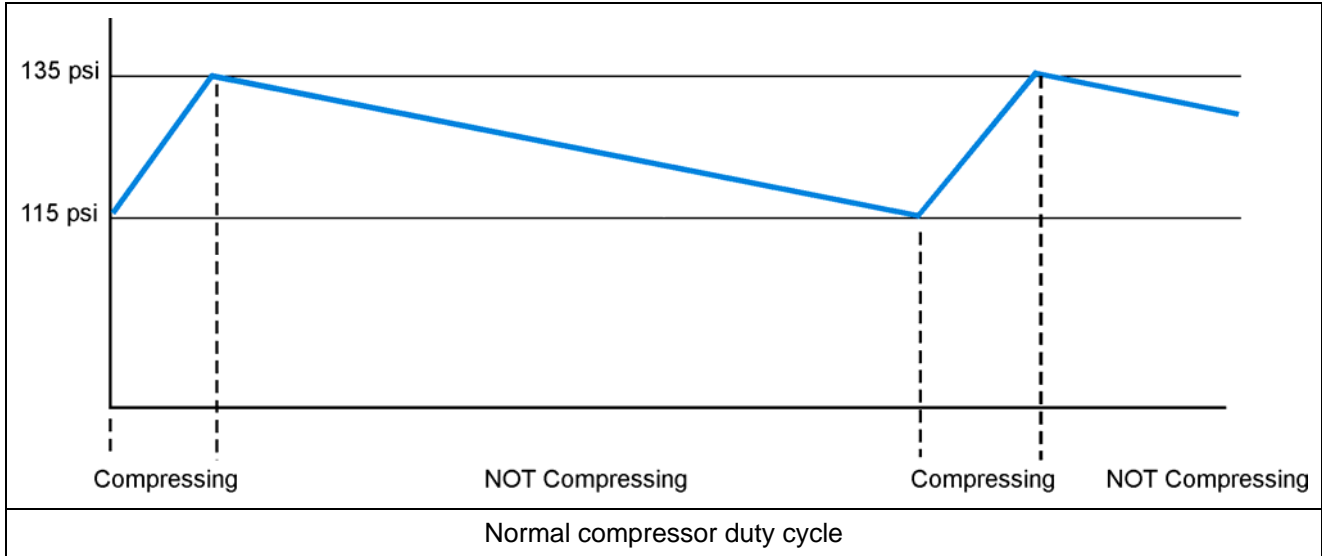

As an example, if a major air leak existed the compressor could be on for 10 seconds and off for 10 seconds. This does 2 things:

1. The compressor duty cycle is 50% which will cause excessive compressor heat and increased wear. The heat and wear will cause the *normal* oil leakage past the rings into the head of the compressor to carbonize, resulting in stuck unloading components and eventual compressor failure.
2. The dryer will not have time to properly purge out moisture and contaminants and these will be passed into the air system.

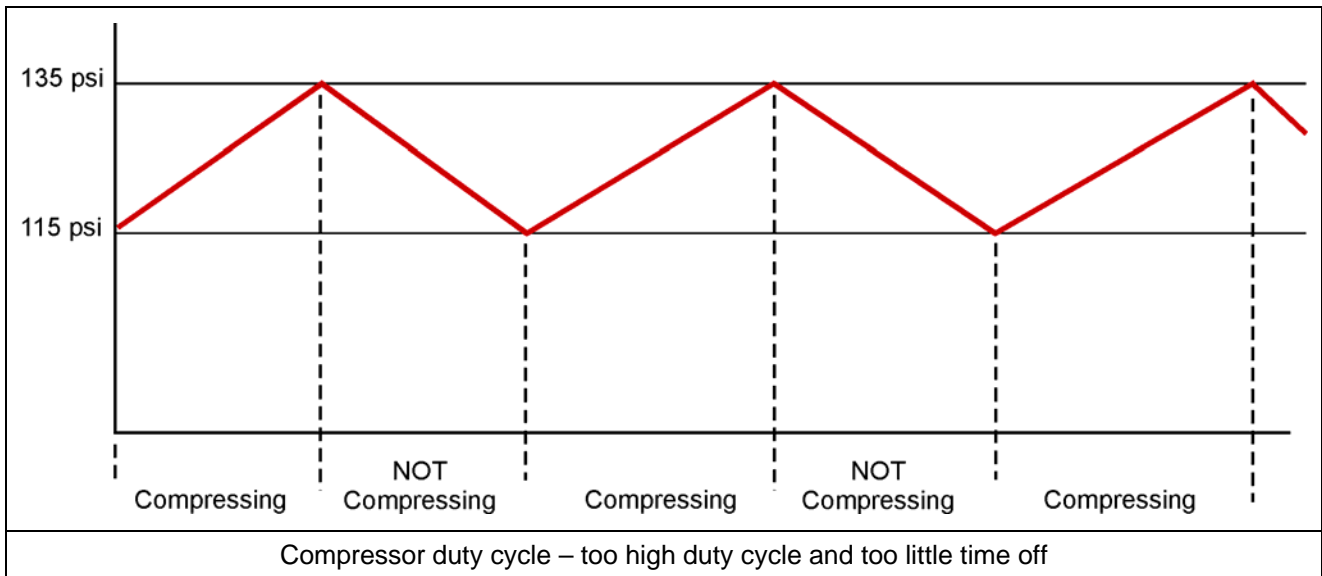

Testing of the Klens system, air brakes, air horn and other air systems for flow requirements with flow meters showed that the various air compressors in use have sufficient capacity for a properly functioning air system. The same testing showed that none of the various compressors currently in use had capacity to cope with a major continuous air leak.

Air Leaks:

When a major air leak was introduced into the system, the compressor duty cycle increased. Depending on the severity of the leak, the entire capacity of the compressor could be lost. Two key areas for major leaks were identified as being the hydraulic tank and the Klenz system. Both of these areas are isolated from the main air system by solenoids, orifices and regulators.

- The solenoids will stop air flow to both areas when the machine is booted down for maintenance and any air leaks will not be heard.

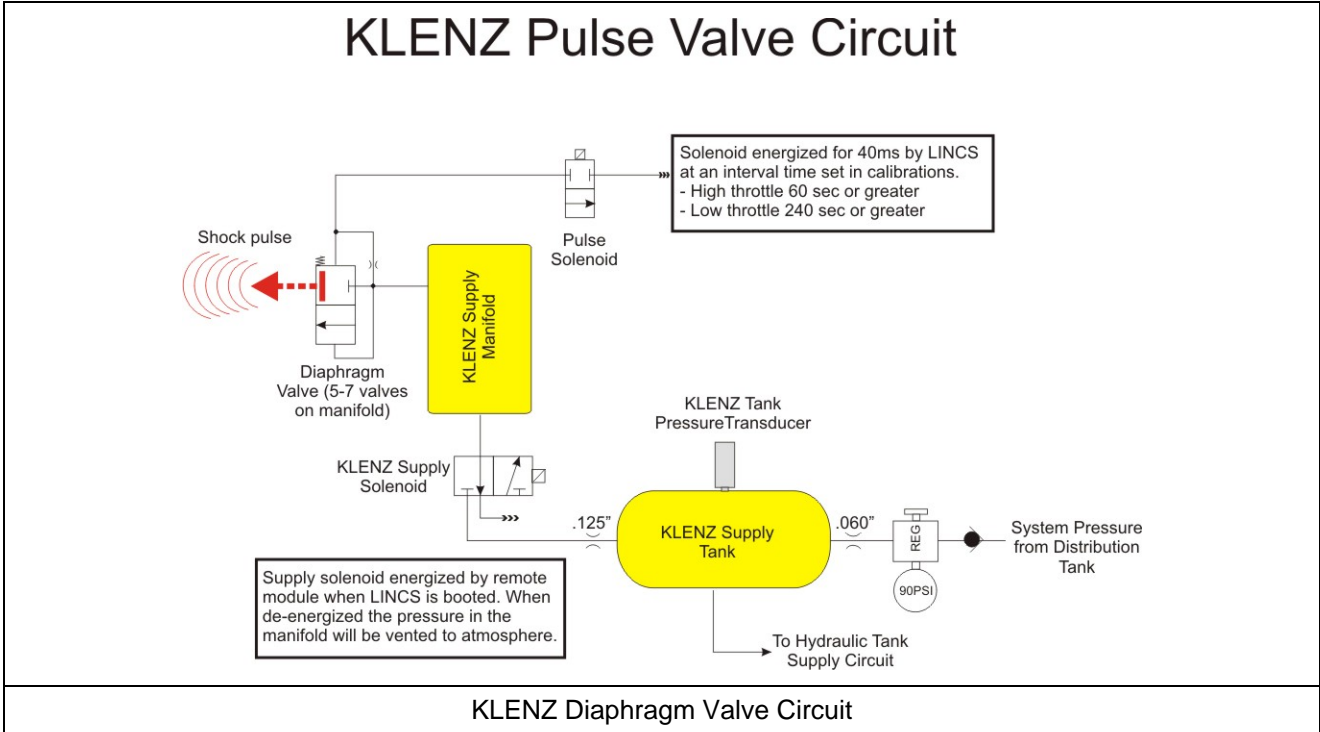

- KLENZ
 - Is isolated behind an orifice in the air line to prevent surges in the main air system when the KLENZ valves pulse.
 - However, this orifice also limits air flow to the KLENZ system – so if there is a major air leak in the KLENZ system the compressor will typically be able to maintain main system pressure so the machine can continue to operate – but at a very high compressor duty cycle.

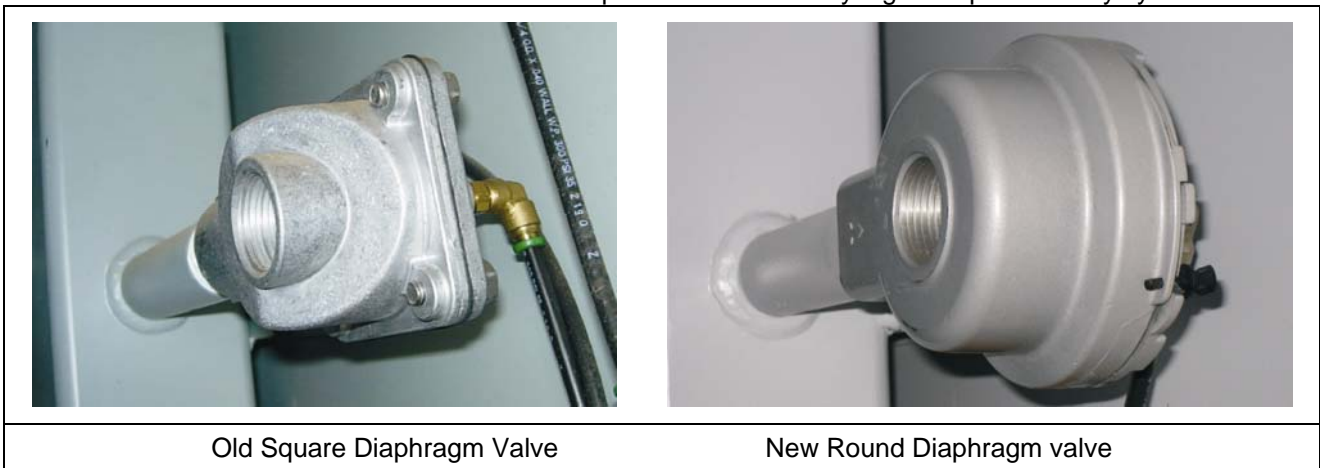

- Hydraulic tank

- The existing pressure regulator for the hydraulic tank is a 0-60 psi regulator and may not be accurate and repeatable when regulating at the specified 6 psi.
- The pressure transducer use to monitor the hydraulic tank air pressure is 0-50 and may not be that accurate and repeatable at the normal tank pressures
- Due to the inaccuracy - the regulator typically has to be set too high which causes air to bleed off at the 12 psi relief and the 13.8 psi relief in the hyd tank cap
- With incorrect settings the compressor will typically be able to maintain main system pressure – but at a very high duty cycle

Change to DLU

Another change that is being made is to use Discharge Line Unloading or DLU. In the past the compressor would unload in the head as shown.

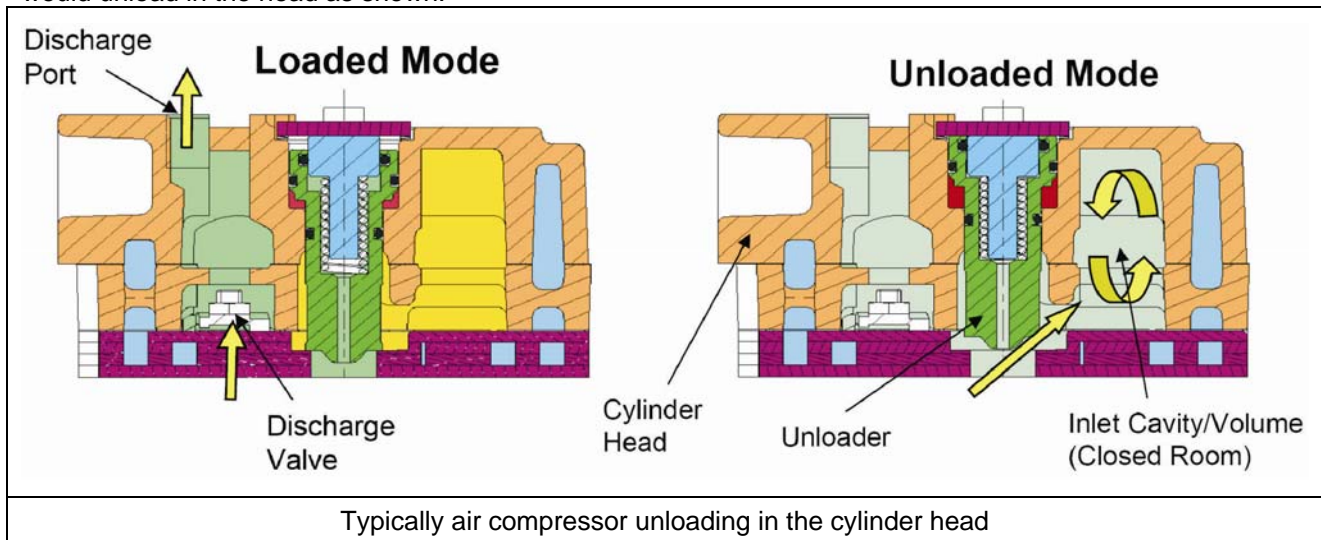

In the DLU system the air compressor moves air all the time. DLU eliminates the need for the unloading mechanisms in the head of the compressor. The unloading mechanism is usually the first point of failure in a high duty cycle compressor application such as the loader. The unloader mechanism in the head cannot fail if it is not used.

The dryer is modified so that when the compressor is off – the air is exhausted out the bottom of the dryer and compressor has a load of about 10-15 psi.

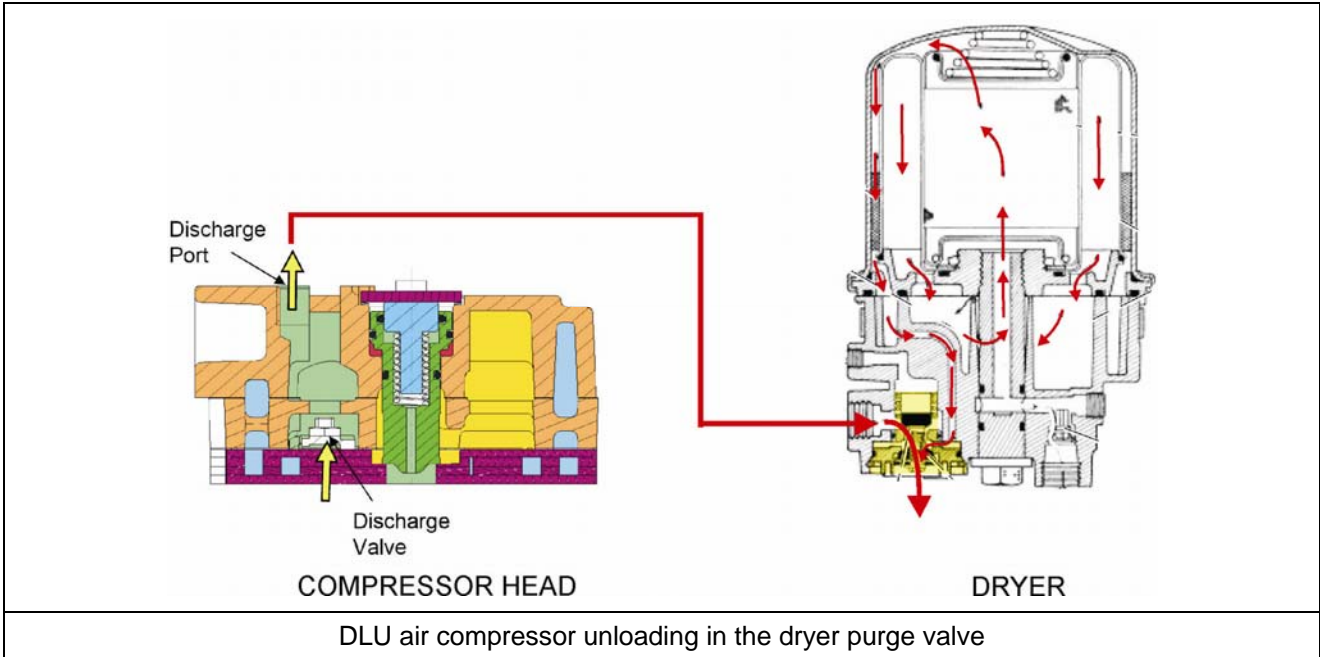

When the compressor is on the air is directed at high pressure through the dryer and into the air system.

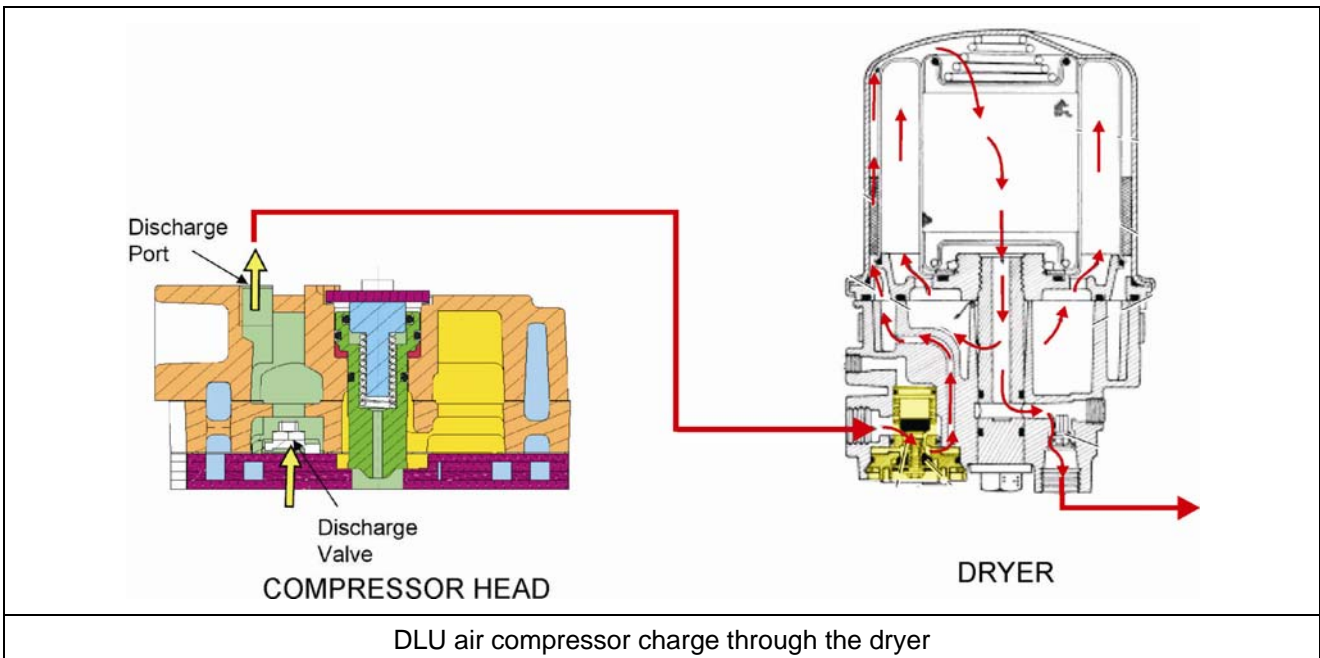

This same system may have been installed on several machines using the Versa Valve Unloader valve instead of the modified dryer valve. The system functions the same except that the Versa Valve Unloader directs air flow to either atmosphere (unloaded) through the muffler or blocks flow and the flow goes through the air dryer.

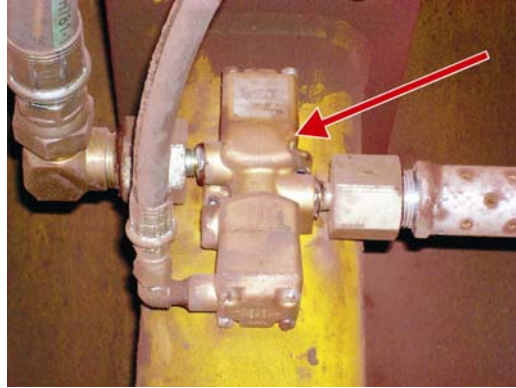

Versa Valve Unloader

NOTE

The compressor and dryer must be in good condition when the change is made to DLU. If the compressor and head unloader is near to failure – the change to DLU and the other air system changes will not prevent the failure. The dryer must also been in good condition and not leaking.

LINCS software monitoring:

LINCS will monitor various aspects of the air system performance as listed below

- LINCS will look at the distribution tank air pressure fluctuations to determine the duty cycle of the air compressor.
 - If the duty cycle is above nominal 40% an alarm will be generated. This value can be set by a person with a “factory rep” level ibutton to a value between 25% and 75%
 - The duty cycle is based on a 5 minute average + a 2 minute alarm delay.
 - The alarm is ignored for 10 minutes after the engine is started so that it can survive an empty air system that has to be charged.
 - The alarm will repeat every two minutes unless the problem is corrected.



Massive air leak causing high air compressor duty cycle

- LINCS will look at the pressure transducer and cable for proper function. If the 4-20 ma transducer is below 2 ma or above 22 ma an alarm will be generated.
 - For the 0-200 psi KLENZ tank transducer the approximate values for this alarm will be below -25 psi or above 243 psi.
 - For the 0-15 psi hydraulic tank transducer the approximate values for this alarm will be below -2 psi or above 17 psi.



Failure of transducer or cabling

- LINCS monitors the KLENZ filter restriction for signs that the filters are plugged
 - If the restriction is too high it will generate a yellow warning and at a higher restriction a red alarm



Failure of transducer or cabling

- LINCS will look at the pressure in the KLENZ tank for signs of a massive air leak in either the hydraulic tank or the KLENZ system
 - If the KLENZ tank air pressure does not build to 80 psi then LINCS will generate an alarm. (This air pressure is ignored for the first 10 minutes after the engine is started)



Massive air leak

- After the engine has been running for more than 10 minutes LINCS will look at the pressure in the hydraulic tank for signs of a massive air leak.
 - If the hydraulic tank air pressure is below 3 psi for more than 45 seconds then LINCS will generate a yellow warning.
 - If the pressure drops below 3 psi for more than 3 minutes then LINCS will generate a red alarm
 - The alarm will reset if the pressure is above 4 psi for more than 2 seconds



Hydraulic Tank Air Pressure Low

NOTE

If the hydraulic tank oil level is proper the pressure will normally fluctuate about 3 psi between the hoist down and hoist up positions. If the regulator is set to 6 psi then the pressure should typically fluctuate between 6 and 9 psi.

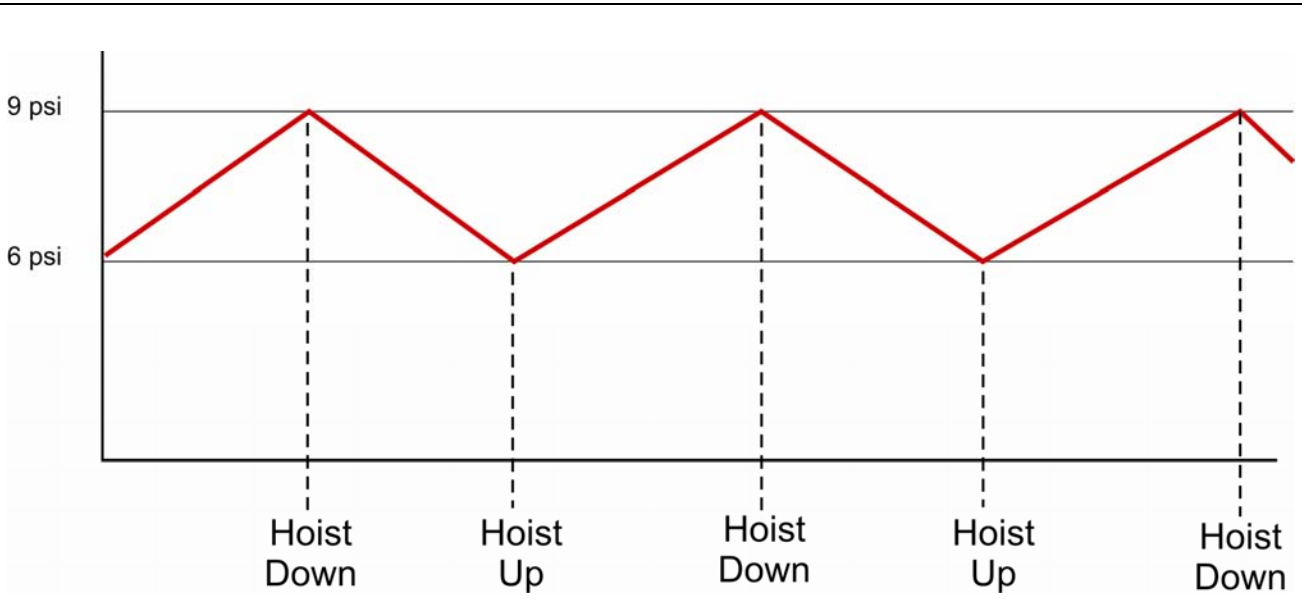

Hydraulic Tank Air Pressure Low

- LINCS will look at the fluctuations in the KLENZ tank for signs that a diaphragm valve is not firing.
 - If the KLENZ tank pressure does not drop by 10 psi when LINCS sends a signal to fire a solenoid and trigger the diaphragm valve, then LINCS will generate a message indicating that a solenoid is not firing.
 - The X in the message below will actually be a number.
 - The number refers to the solenoid number.
 - (1-5 for 950, 1-6 for 1350 and 1-7 for 1850/2350)
 - If a solenoid does not fire for 5 consecutive cycles the message will be elevated to a yellow alarm.



Solenoid not firing

- LINCS will look to see if the power switch is turned on
 - If the power switch is off – a yellow warning will be generated.



Solenoid not firing

- LINCS will look to see if the KLENZ solenoids are being commanded to fire.
 - If the KLENZ switch is on, there is air pressure in the KLENZ tank and the solenoids are not being told to fire, LINCS will generate a message indicating that solenoids are not working.



Solenoids not working

- LINCS will monitor the emergency stop (E-stop) switches on the hydraulic tank, electrical cabinet, cab, right battery box and left battery box.
 - If an E-stop switch is activated the air will be released from the hydraulic tank by the dump valve.
 - The dump valve and E-stop switches have to be manually reset.



Solenoids not working

Section 2:

OVERVIEW OF UPDATE

Blank on purpose for double sided printing

L/D-950/L-1350 / L-1850 / L-2350 Air system changes

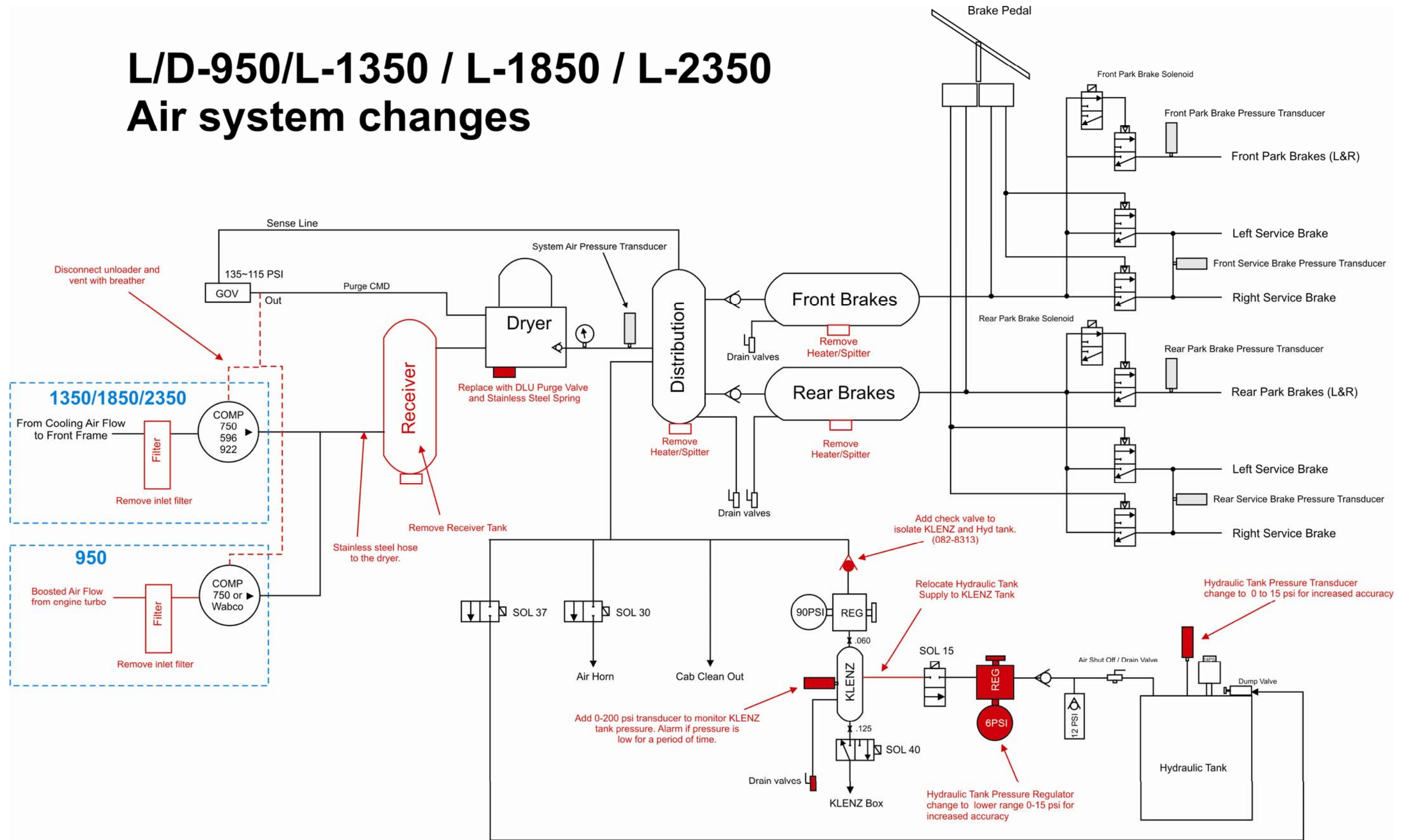

Empty page on purpose for double sided printing

Overview of Update

- **Remove all automatic drain (spitter) valves from the bottom of the air tanks** – These automatic drain valves cannot reliably pass contaminants and by their name “automatic” lead people to believe that the manual draining of the tanks is not necessary. This is a high volume system and the tanks must be manually drained by the operator at the beginning of each shift.

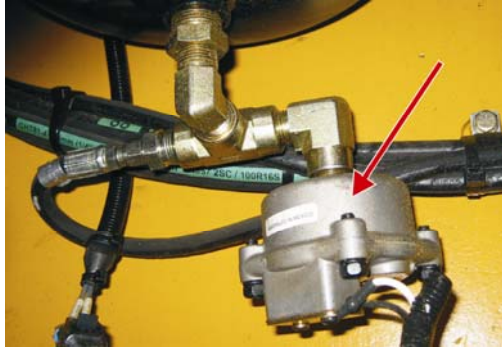

Typical automatic drain (spitter) valve

- **Remove the receiver tank** – The receiver tank was added between the air compressor and the air dryer to act as a heat exchanger to reduce the inlet temperature to the dryer. It failed because the automatic drain valves could not handle the quantity of moisture generated in certain climates nor the acidity of the water captured. Additional testing has confirmed that a length of SS hose provides similar heat reduction without the potential of rust introduction. This hose must be constructed of stainless steel braided material so it cannot rust.



Remove “receiver tank”

- **Remove filter from the inlet to the compressor** – the current filter creates a restriction on the inlet. If the filter becomes excessively dirty this may cause extra oil to be drawn up into the head of the compressor contributing to the carbon build up. The compressor inlet air is already filtered by the KLENZ filters.

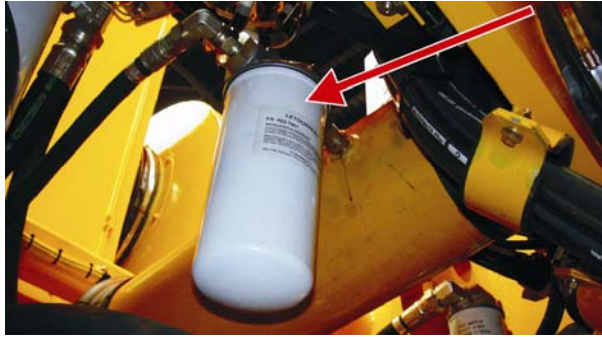

Remove air compressor inlet air filter

- **Disconnect the governor unloading circuit at the compressor** – Bendix has told us that the unloading components of the 596 compressor are susceptible to carbon build up failure. They recommend disconnecting the head unloading circuit and using a discharge line unloading (DLU) system that will allow the compressor outlet to be discharged to atmosphere when the governor setting is reached.



Disconnect the head air unloader

NOTE

The governor will still be used to control the air dryer purge valve.

- **Remove the Syncro valve**
 - Disconnect and remove the Syncro valve attached to the governor. This was required to make the 596 compressor unload properly and is not required with the DLU system.



Remove the Syncro valve

- **Install the DLU purge valve.** – This valve replaces the original purge valve and allows the compressor outlet to be vented to atmosphere through the purge discharge port when the governor setting is reached.

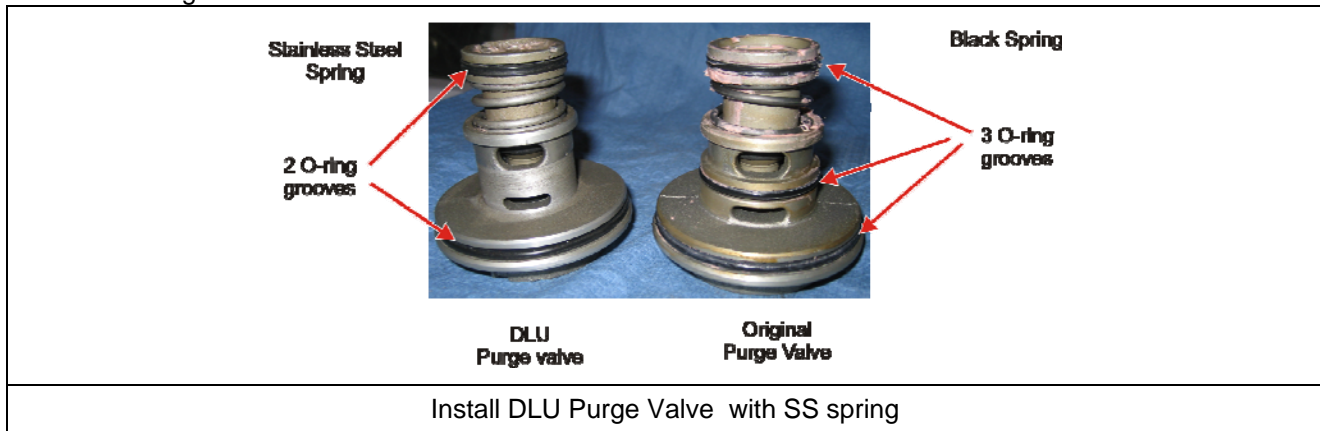

- **Insure 596 compressor has relief in head** – Should be set at 250psi.



- **Relocate the hydraulic tank supply** from the distribution tank to the KLENZ supply tank. The inlet orifice of the KLENZ tank would limit the air loss due to a leak in the tank air supply circuit.
- **Verify that the orifices** to the KLENZ system are properly installed and not contaminated. We tested the system without the orifices and the normal function of the KLENZ system caused pressure drops that affected the main air system. The testing proved that the orifices are required and they prevent the KLENZ from affecting the main system.
 - The orifices are drilled set screws installed into the adapter fittings that go in the inlet and outlet of the KLENZ air tank. .062"/1/16" (1.6 mm) on inlet and .125"/1/8" (3.2 mm) on outlet.

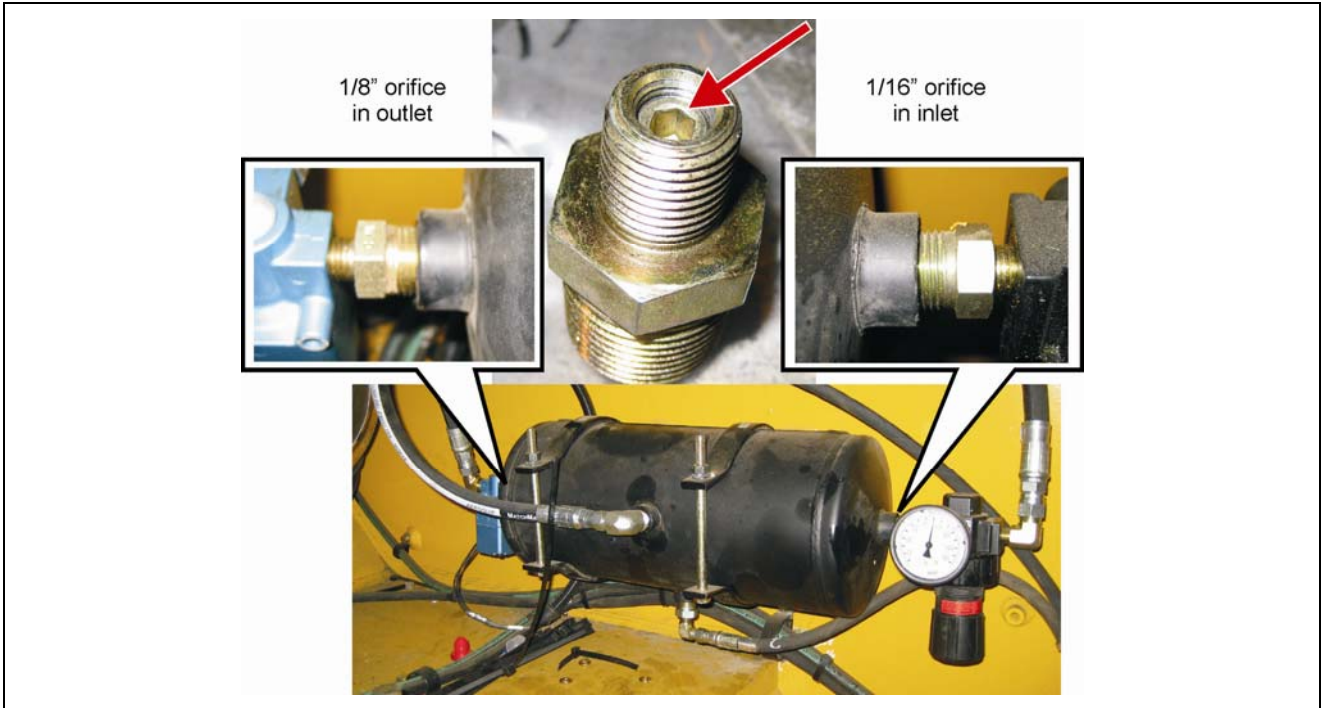

KLENZ tank orifices

- **Add a check valve to isolate the KLENZ and hydraulic tank air supply.** This will assist in troubleshooting.

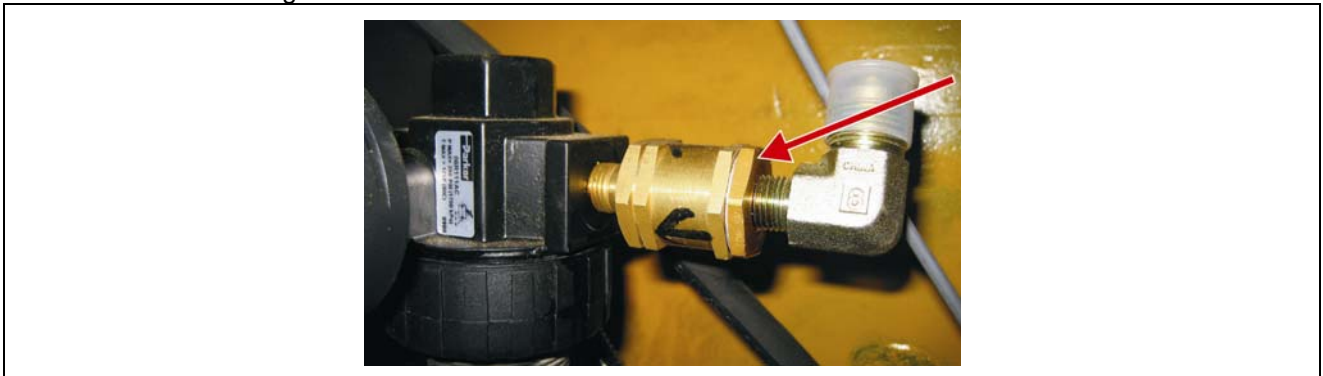

KLENZ tank orifices

- **Replace the hydraulic tank supply regulator with one of a lower setting range.**

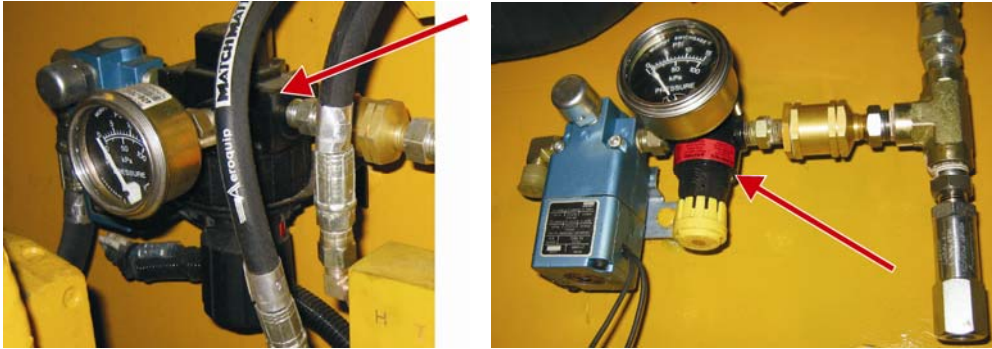

Replace the original air regulator

- **Replace the existing 0 to 50psi hydraulic tank pressure transducer with one with a 0 ~ 15psi range.**

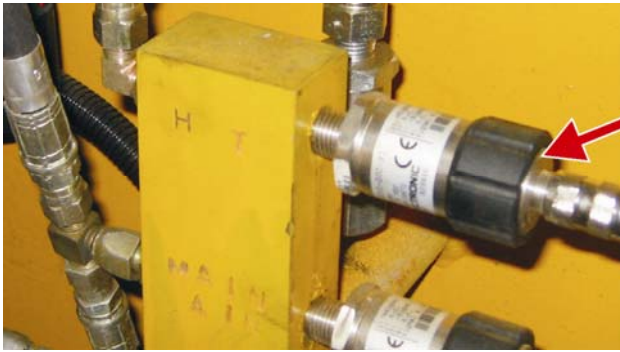

Replace air transducer

- **Add a transducer to monitor KLENZ tank pressure.** If pressure fails to be reached or is unable to be maintained an alarm will sound alerting the operator. This transducer will also be used to monitor the diaphragm valves to assure that they are properly firing. Note that an adapter cable may be required depending on machine wiring system.

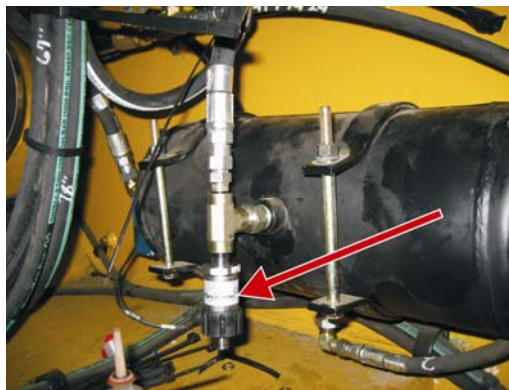

Add Klenz tank pressure transducer

- **Install new configuration**
 - monitor KLENZ tank transducer for:
 - proper solenoid firing
 - loss of air
 - monitor 0-15 transducer for hydraulic tank
 - monitor compressor duty cycle

- **On the L/D-950 the inlet of compressor will come from the turbo boost of the engine.**

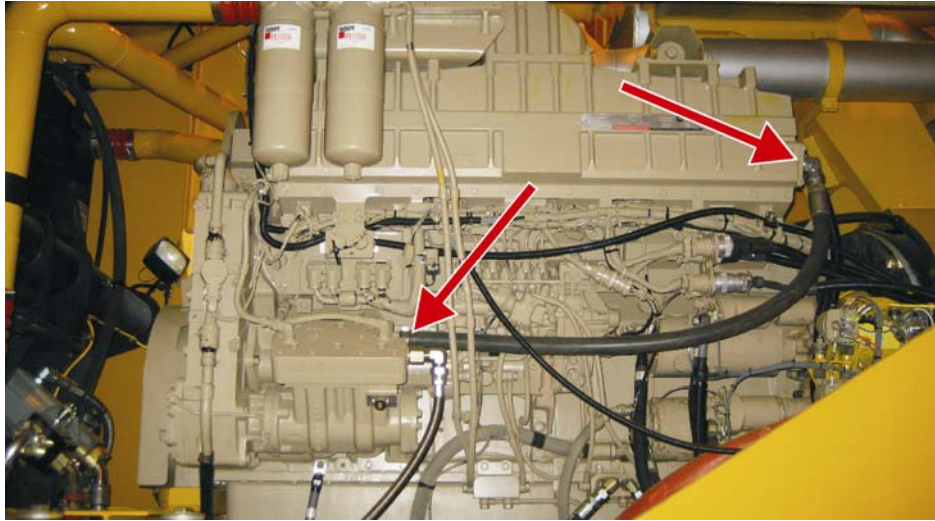

950 Cummins air compressor boosted by turbo air

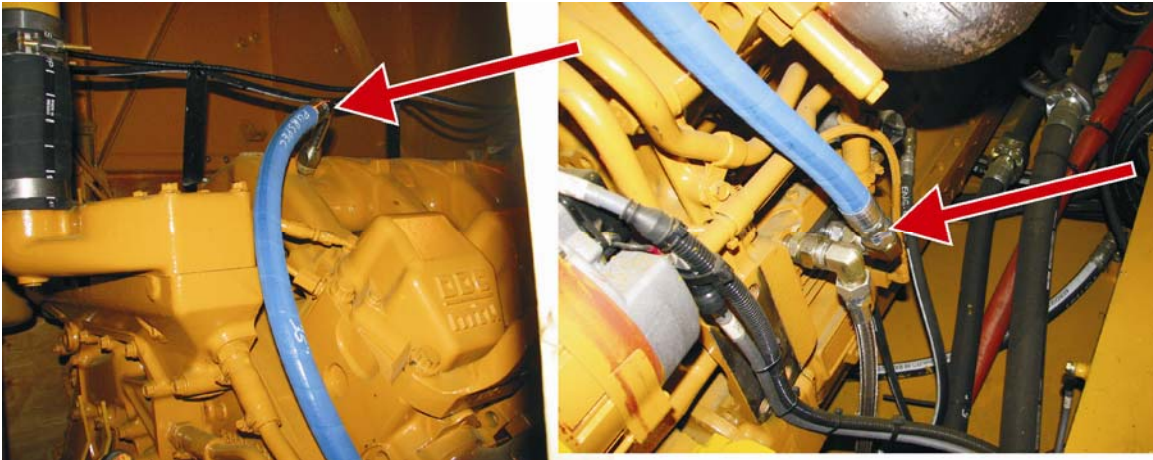

950 Detroit air compressor boosted by turbo air

Section 3:

PARTS LIST FOR UPDATE KIT

Blank on purpose for double sided printing

Parts List – 426-4841 Update Kit

NOTE

The following list should take care of updating the air system on most machines – but there may be local variations in air system plumbing that this kit will not cover and it is possible that some additional parts may be required.

Parts list 426-4841 air system update kit			
Item	Qty	P/N	Description
1	1	426-1746	Stainless steel hose
2	5	098-6146	Hose clamps
3	1	082-4753	5/16 X 1 ¼" bolt
4	1	082-1687	5/16 nut
5	5	057-6803	3/8" NC X ½" Bolt block
6	5	081-0970	3/8" X ¾" Bolt
7	5	080-8221	3/8" flat washer
8	5	075-3123	3/8" lock washer
9	6	422-3338	8NPT plug
10	6	401-3780	6 NPT plug
11	6	401-3779	4 NPT plug
12	2	412-3615	#4 FJ Cap <i>(Not in the procedures - extra item in case needed)</i>
13	2	411-6536	#6 FJ Cap <i>(Not in the procedures - extra item in case needed)</i>
14	2	412-3618	#4 FJ Plug <i>(Not in the procedures - extra item in case needed)</i>
15	2	412-3620	#6 FJ Plug <i>(Not in the procedures - extra item in case needed)</i>
16	2	401-3789	8 MP X 6 FP bushing <i>(Not in the procedures - extra item in case needed)</i>
17	4	401-3788	8 MP X 4 FP bushing
18	3	401-3787	6 MP X 4 FP bushing
19	1	401-6785	4 MP X 4 MJ Straight adapter
20	1	401-1748	4 MP X 4 MJ 90° Elbow adapter
21	1	417-1482	6 MP X 4 MJ 45° Elbow adapter
22	3	403-2312	6 MP X 6 MP straight nipple adapter
23	1	403-1446	4 FP X 4 FP X 4 FP tee
24	1	052-7116	4 MP X 6 MJ adapter
25	1	407-6887	8 MP X 4 MP Nipple
26	1	415-8827	4 FJ swivel X 1/8 FP adapter fitting
27	4	071-6331	1/8 NPT socket plugs
28	1	695-3864	#6 MP X #4 MJ 90° Elbow adapter
29	1	426-1747	Front Frame air bleed bracket

Parts list 426-4841 air system update kit			
Item	Qty	P/N	Description
30	2	415-2842	Ball valve
31	4	081-0986	¼ X ¾ bolt
32	4	021-3584	¼ lockwasher
33	4	401-0923	1/4 flatwasher
34	5	401-0290	¼ X ½ bolt block
35	1	425-5494	0-200 psi Pressure Transducer kit (<i>includes 425-5489 pressure transducer and 425-5449 crossover adapter cable – blue</i>)
36	1	425-5449	Adapter cable (1 Included in 425-5494 kit – 1 additional for hyd transducer)
37	1	425-1687	Turck extension cable 10 meter
38	2	425-1784	Turck EURO connector (for non Turck wired machines)
39	1	426-5196	0-15 psi transducer
40	1	426-4840	0-15 psi air regulator (may also be 0-10 psi)
41	1	082-8313	Check valve
42	1	425-7638	Solenoid bar mount
43	6	401-0907	Lockwasher #10
44	2	006-0043	Machine screw #10 NC X 1 3/4"
45	1	424-4790	Breather check valve
46	2	426-1581	Spring stainless steel for purge valve
47	1	425-8483	Purge valve kit
48	1	407-3656	Klenz tank drain hose 1850 90" #4
49	1	405-5426	Klenz tank drain hose 1350 192" #4
50	1	403-0310	Hyd tank air supply hose 1850 #6 X 92"
51	1	415-3297	Hyd tank air supply hose 1350#6 X 140"
52	1	425-8493	Exhaust hose for Dryer 60"
53	1	051-9707	SS hose clamp 2 »
54	1	410-3739	Loctite 545 Hydraulic Thread Sealant 50cc
55	2	425-5196	Klenz diaphragm valve (round)
56	2	422-3339	#12 MP plug
57	1	424-4688	M22 X 4 MJ straight adapter
58	1	425-5667	175 psi pressure relief
59	1	425-6397	12 psi check valve
60	1	425-8491	Exhaust cover
61	1	124-4105	10-24 Spiral tap
62	4	401-2422	PH #10-24 x 5/16"

Additional Parts listed below will be required if machine does not have KLENZ tank
 (These parts are not included in the kit listing above)

Item	Qty	P/N	Description
1	2	404-0563	Fitting 90° Elbow 8 MJ X 4 MP
2	1	410-3792	Air regulator
3	1	424-4824	Pressure gauge
4	1	425-6313	Assy orifice .062 0 8 MP X 4 MP Klenz tank inlet
5	1	408-1394	Air reservoir 587 cu in, 150 psi working pressure (KLENZ tank)
6	1	425-6312	Assy orifice .125 0 8 MP X 4 MP Klenz tank outlet to Klenz system
7	1	403-9803	Solenoid Valve - air - 3way - 24vdc
8	1	416-2499	Breather vent for solenoid valve
9	2	400-7414	Mounting bracket
10	2	425-7004	Weld on Bar mount with bolt blocks
11	4	081-0971	Bolt 3/8" NC X 1
12	4	080-8221	Washer 3/8"
13	4	075-3123	Lockwasher 3/8"

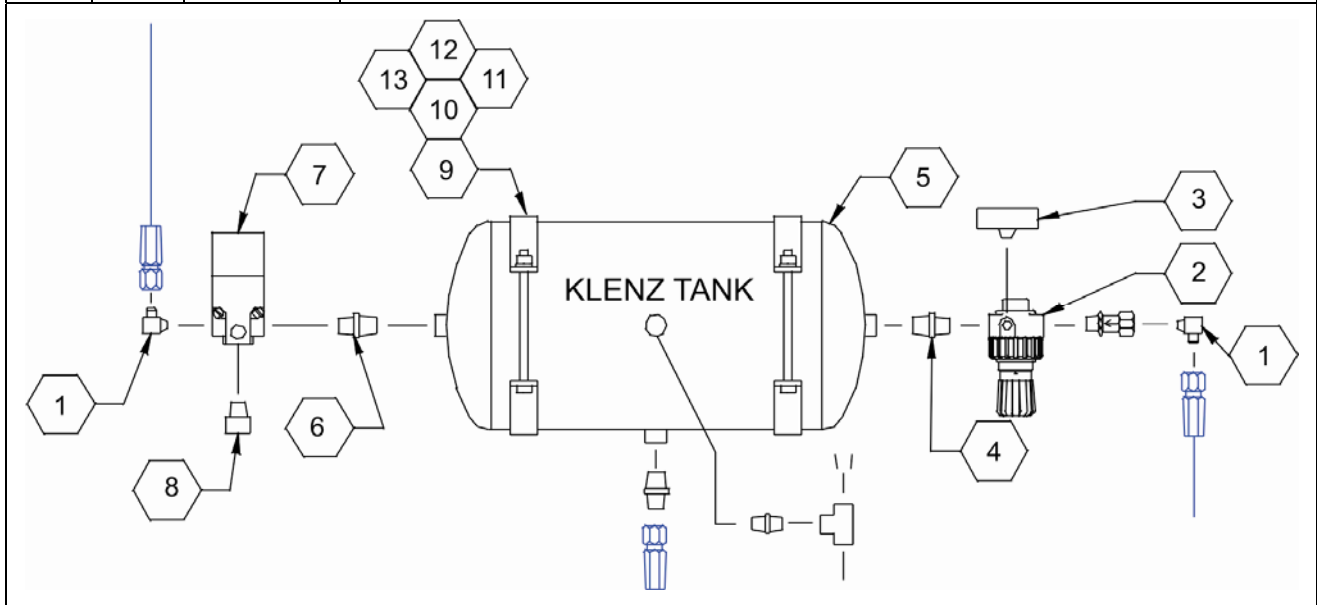

Additional Parts listed below will be required if machine does not have Bendix air dryer

(These parts are not included in the kit listing above)

Item	Qty	P/N	Description
1	1	425-8485	Dryer, air - Bendix
2	1	425-8480	Mount, air dryer
3	1	424-4689	FTG HYD 90 12 MJ 12 FJ MOD
4	2	401-5753	FTG HYD 0 12MJ 8 MP JUMP
5	1	424-4824	Gauge, air 160 PSI
6	3	080-1180	Bolt HX .500 1.000 NC G8 FT
7	3	081-0991	Washer flat .531 1.062 .121
8	3	080-1181	Washer lock SPR .500 .873 .125
9	4	400-9640	Bolt HX .375 1.500 NC G8
10	4	080-8221	Washer flat .375 .81 .08
11	4	075-3123	Washer lock SPR .375 .68 .09
12	1	425-8493	Exhaust hose
13	1	071-1253	Clamp hose worm dr
14	1	425-8491	Exhaust cover
15	1	401-6785	FTG HYD 0 4MJ 4MP
16	1	027-2969	Pipe plug .250 SC HX

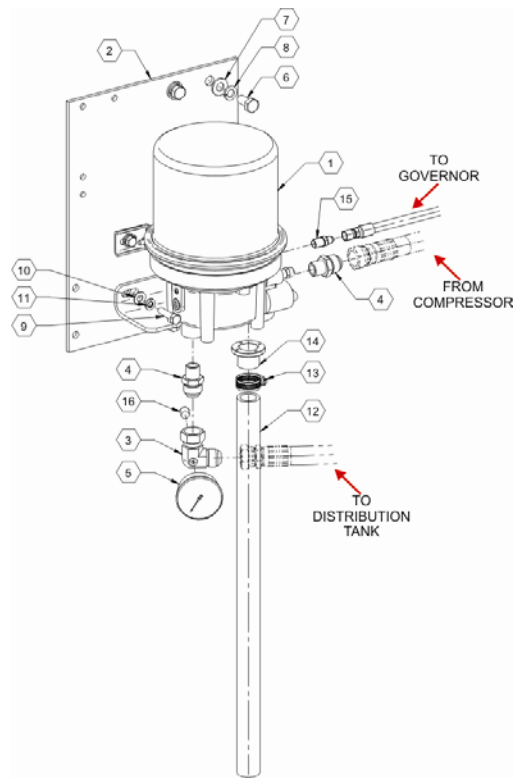

Section 4:

DETAILED INSTALLATION PROCEDURE

FOR

UPDATE KIT

Blank on purpose for double sided printing

Detailed Installation Procedure for Update Kit

CAUTION

All air drain valves should be opened and all system air removed prior to working on the air system. Working with compressed air on the system would be dangerous.

NOTE

This work list is generic and does not cover every possible air system configuration that may be in use. Modifications and changes may be required on a specific machine in order to meet the specifications. Contact LeTourneau Technologies Product Support department with any questions regarding this installation and update.

NOTE

Use 410-3739 Loctite® 545 Hydraulic Thread Sealant on all JIC, MP (NPT) and FP (NPT) joints.

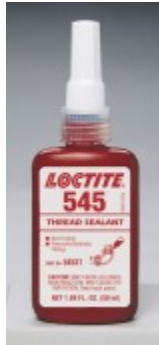

Abbreviations used for describing fittings

MP	=	Male NPT pipe thread
FP	=	Female NPT pipe thread
MO	=	Male SAE Boss O-ring fitting
MJ	=	Male JIC fitting
FJ	=	Female JIC fitting
4	=	¼"
6	=	3/8"
8	=	½"
12	=	¾"

The drawing on the next two pages show the parts that are to be removed and those to be installed

Blank on purpose for double sided printing

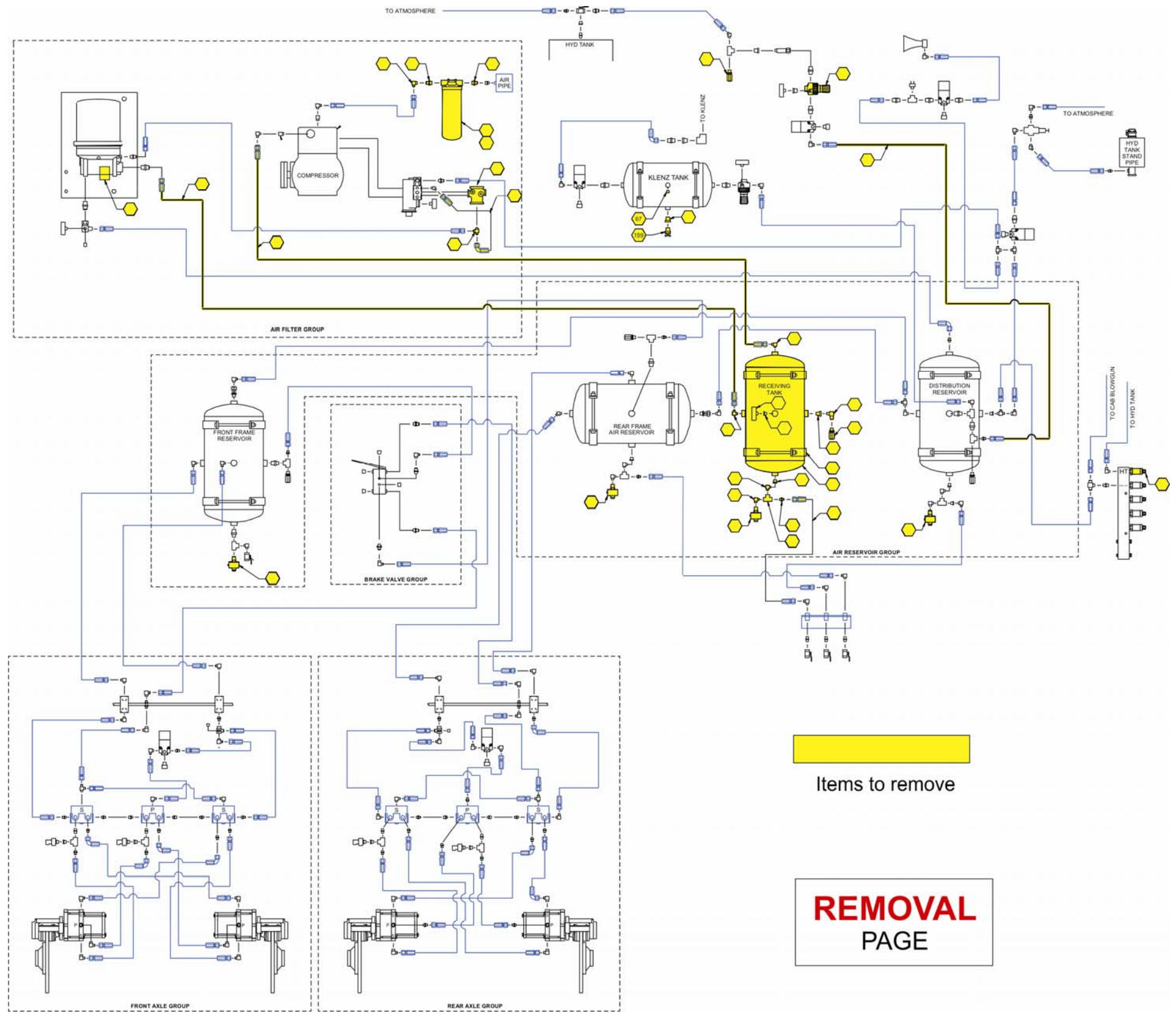

Items to remove

REMOVAL
PAGE

Items to be removed

Blank on purpose for double sided printing

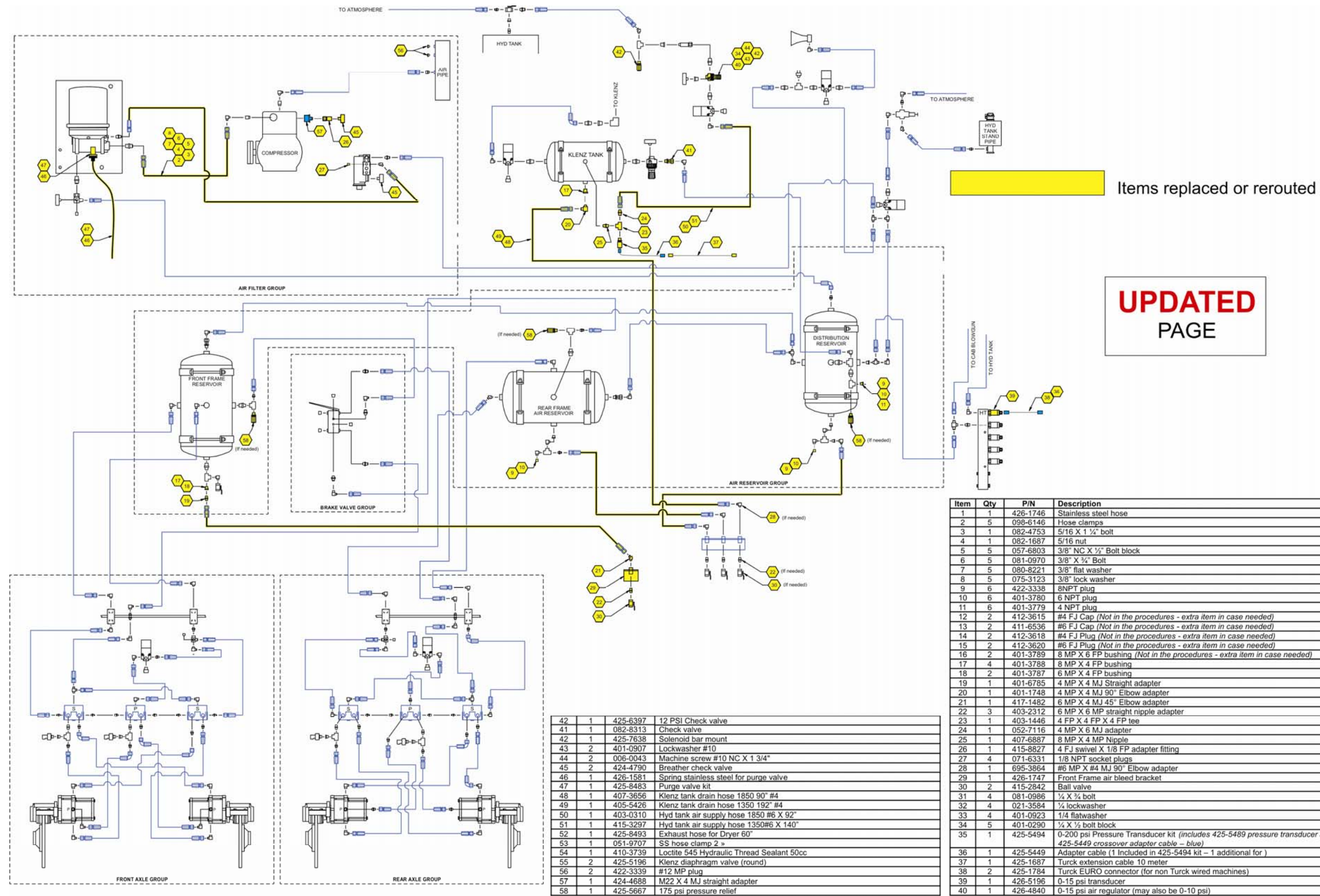

Update installation

Blank on purpose for double sided printing

1. Remove the air filter on the inlet air (all machines)



Remove air inlet filter

- a. Leave the 424-4753 12 MP X 12 FJ swivel adapter fitting in the side of the air duct. (This P/N provided for reference purposes only. It is not included in the kit)
- b. Connect the air hose to the fitting.
- c. (This was only installed on some machines)
- d. Note that the 950 may have a compressor intake filter located in a different location on the side of the engine. It should also be removed.

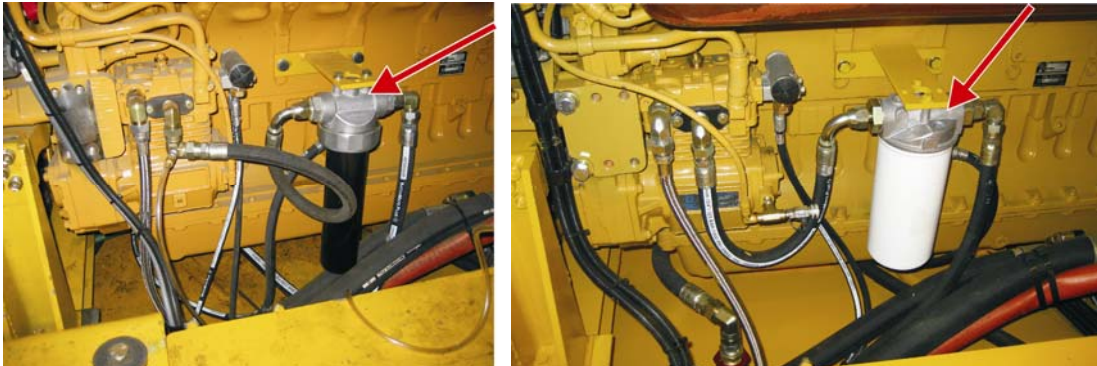

Remove 950 compressor inlet filter

2. Remove the air cooler in the air duct



Remove air cooler in air duct

- a. (This only applies to 3-4 machines built in early 2008)
- b. Plug the two holes through the tubing wall with 422-3339 #12 MP plug.

NOTE

Once completed – the air compressor inlet air will come from a fitting in the air duct to the front axle.

NOTE

On the 950 the air will come from the engine. This can only be done with Bendix 750 or the Wabco compressor. DO NOT use engine turbo air to pressurize the 596 or 922 compressors as this will overpressure the head and cause damage.

Cummins Installation:

Modify the plate on end of engine. Drill and tap with 16 FP threads (1" NPT)

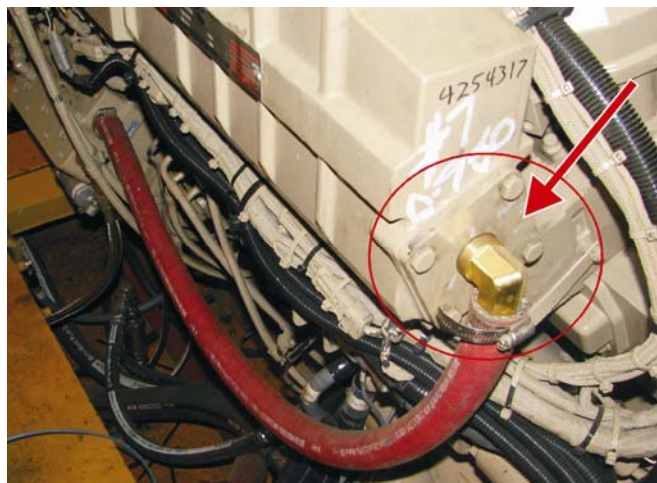

Modify the endplate

(This picture shows an early installation. Current hoses have a JIC fitting on this end – not a hose clamp.)

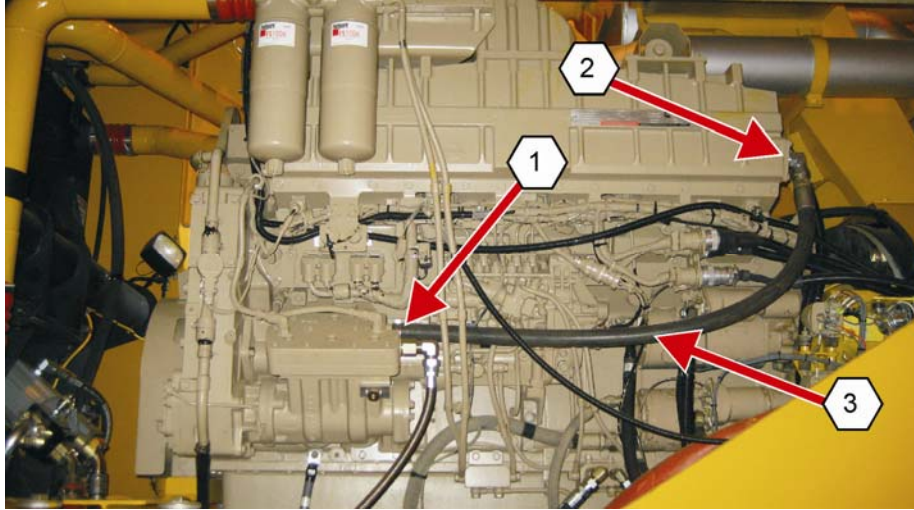

Cummins Boosted Wabco compressor

- 1) 051-9707 2" Stainless Steel clamp (reference only – parts not in the kit)
- 2) 400-2443 90° Elbow 16 MJ X 16 MP (reference only – parts not in the kit)
- 3) 426-1765 Hose 16 OJ X no fitting (reference only – parts not in the kit)

Detroit Installation

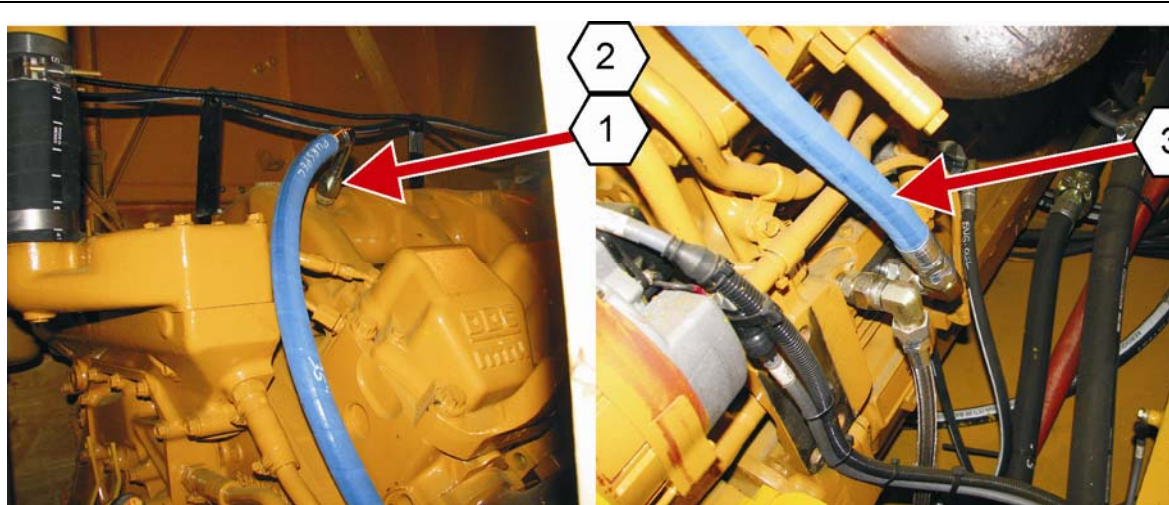

Detroit Boosted 750 compressor

- 1) 426-4802 Fitting Straight 14 MMO X 8 MJ (reference only – parts not in the kit)
- 2) 426-4803 Fitting Straight 8 FJ X 12 MJ (reference only – parts not in the kit)
- 3) 426-1734 Hose 12 OJ X 90 OJ (reference only – parts not in the kit)



Air compressor inlet air from fitting in air duct

3. Remove the receiver tank and related hardware (This tank is typically located in the left side of the rear frame. It was connected between the air compressor and the air dryer) It should be a simple tank with one #12 hose coming in and one #12 hose going out with a bleeder on the bottom.



Remove receiver tank

4. Remove the hose between compressor and receiver tank
5. Remove the hose between the receiver tank and the air dryer
6. Install 426-1746 stainless steel hose between air compressor and air dryer



Install SS hose

- a. Route the hose in a large loop in the area above the PTO box
- b. Use smooth bends – do not kink the hose.

NOTE

This is a new type of stainless steel hose that can have a shorter bend radius than the stainless steel hose with Teflon liner.

- c. Mounting to the bottom corner of the blower exhaust structure as shown in the following figure requires a 082-4753 5/16" X 1 1/4" bolt and extra 082-1687 5/16" nut



Stainless steel hose mounted to bottom corner of blower housing

- d. Use the 098-6146 hose clamps to mount the hose to the bottom of the KLENZ frame structure in several locations.
- e. Mounting the clamps to the other structures will require welding a 057-6803 bolt block to an appropriate location and fastening with 081-0970 3/8 X 3/4" long bolt, 080-8221 3/8 flat washer and 075-3123 3/8 lock washer.



Stainless steel hose mount clamps

- f. The locations for mounting are to be selected for the best routing of the air hose.
 - g. Paint the bolt blocks after welding in place to prevent rust. Paint is not included in the kit.
7. Remove the automatic drain (spitter) valve from the bottom of the rear frame air reservoir.

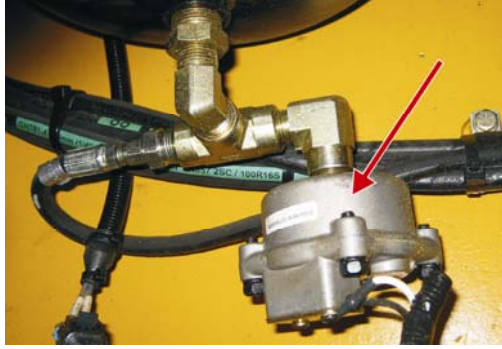

Remove automatic drain (spitter) valves

- a. Install MP plug in the location where the valve is removed (both 401-3780 6 MP and 422-3338 8 MP are supplied in kit) in the location where the automatic drain (spitter) valve was removed.
8. Remove the automatic drain (spitter) valve from the bottom of the distribution air reservoir.
 - a. Install MP plug in the location where the valve is removed (both 401-3780 6 MP and 422-3338 8 MP are supplied in kit) in the location where the automatic drain (spitter) valve was removed.
 9. Remove the automatic drain (spitter) valve from the bottom of the front frame air reservoir.
 - a. Install 401-3788 8 MP X 4 FP bushing. (401-3787 6 MP X 4 FP bushing also included in kit)
 - b. Install a 401-6785 4 MP X 4 MJ adapter in the location where the spitter valve was removed.
 10. Disconnect the following wires from the left side of the DIN rail inside the electrical cabinet. Insulate and secure the wires after disconnecting. These are the wires that were used to power the timer and heater in the automatic drain (spitter) valves that were removed in previous steps.
 - a. 75D
 - b. 75E
 - c. 75F
 - d. 75G

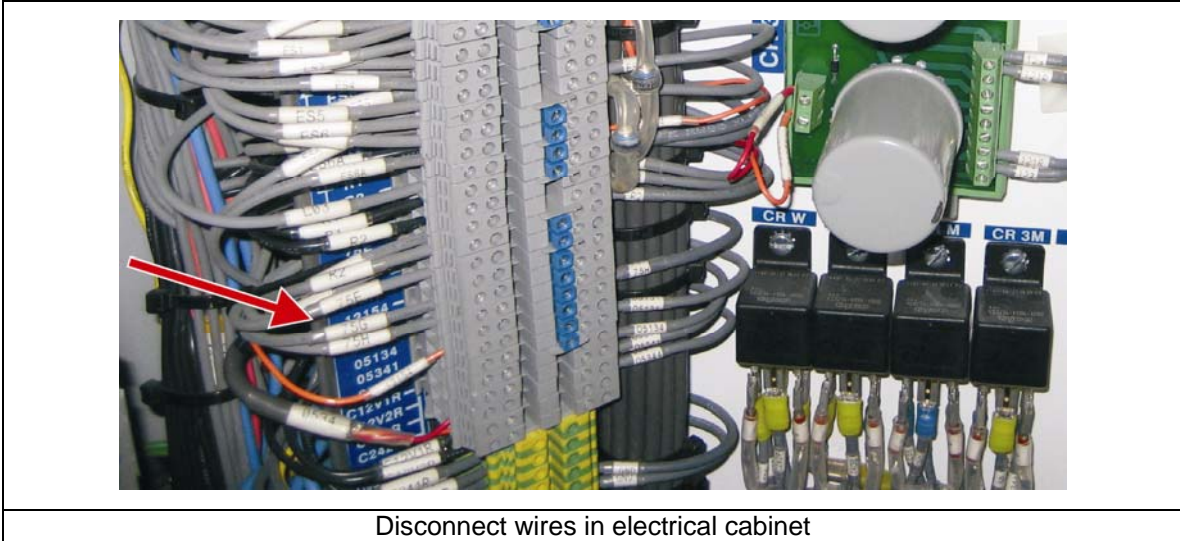

NOTE

Leave the 75H wire in place as this provides power to the heater in the air dryer.

11. Remove the bushing and air valve from the bottom of the Klenz tank.

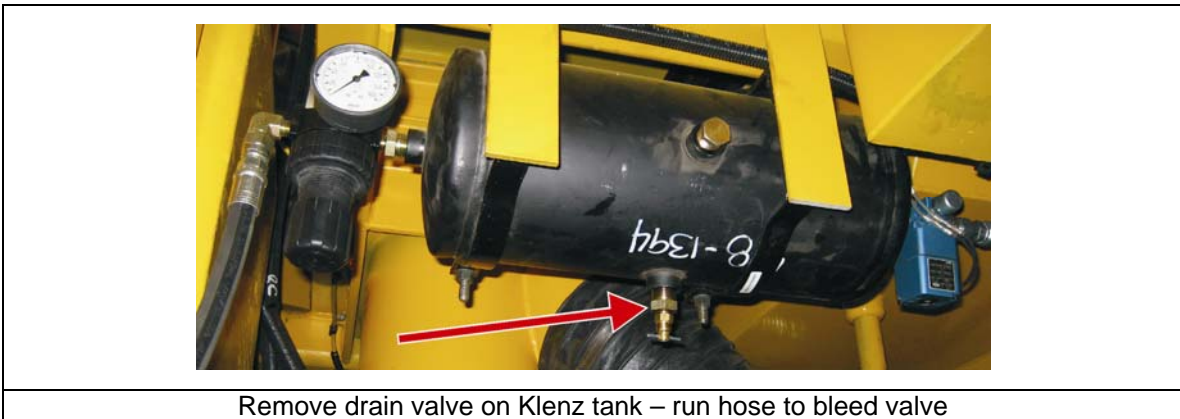

12. Install a 401-3788 8 MP X 4FP bushing into bottom of Klenz tank.

13. Install a 401-1748 4MP X 4 MJ 90° elbow fitting into the reducer.

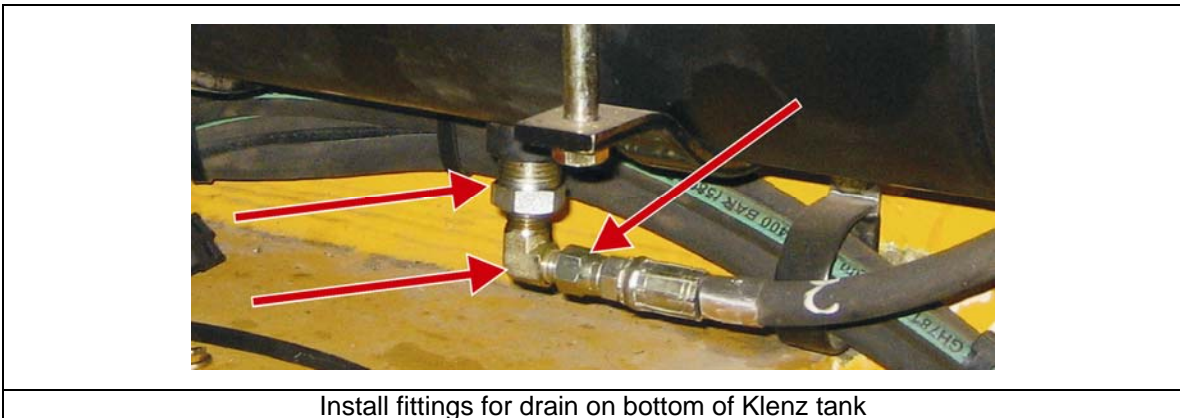

14. Run an air bleed hose from the bottom of the KLENZ tank to the third air bleed valve.
P/N 407-3656 for the 1850/950 and P/N 405-5426 for the 1350.

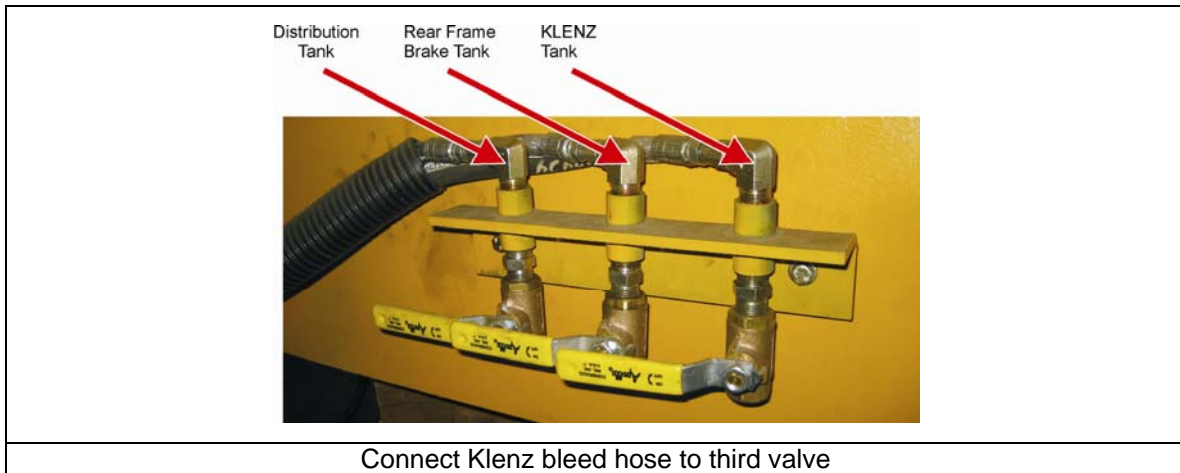

- a. Some machines may be able to use the existing hose on the distribution tank. But on most machines this will most likely require a longer hose as provided in the kit.

NOTE

Some machines may be missing the third drain valve. The parts to install the third drain valve are included in the kit. Use a 6 MP X 4 MJ 90° Elbow adapter on top, 403-2312 6 MP X 6 MP straight nipple adapter with a 415-2842 air valve on bottom.

15. Reconnect the air bleed hose for the distribution tank onto the first air bleed valve (the one on the left)
16. Install an air bleed valve for the front frame tank

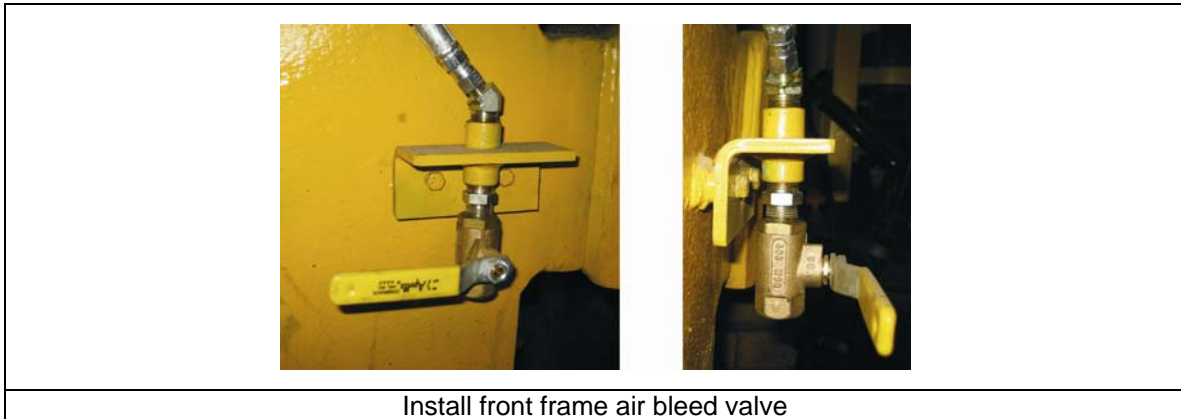

- a. Mount 081-0986 ¼ X ¾ bolts, 021-3584 ¼ lockwashers and 401-0290 ¼ X ½ bolt blocks to the 426-1747 drain mount bracket
- b. Tack weld the bolt blocks in location as shown
- c. Remove the bracket and weld out bolt blocks with ¼" weld
- d. Paint the bolt blocks to prevent rust. (Paint not included in kit)

- e. Install the bracket onto the bolt blocks
- f. Paint the bracket to prevent rust. (Paint is not included in kit)
- g. Install 417-1482 6 MP X 4 MJ 45° Elbow adapter on top
- h. Install 403-2312 6 MP X 6 MP straight nipple adapter on bottom
- i. Install 415-2842 ball valve on bottom
- j. Connect air hose on top

17. Remove the plug in the side of the Klenz tank



Remove plug in Klenz tank

18. Install a 407-6887 8 MP X 4 MP straight nipple in the side of the Klenz tank

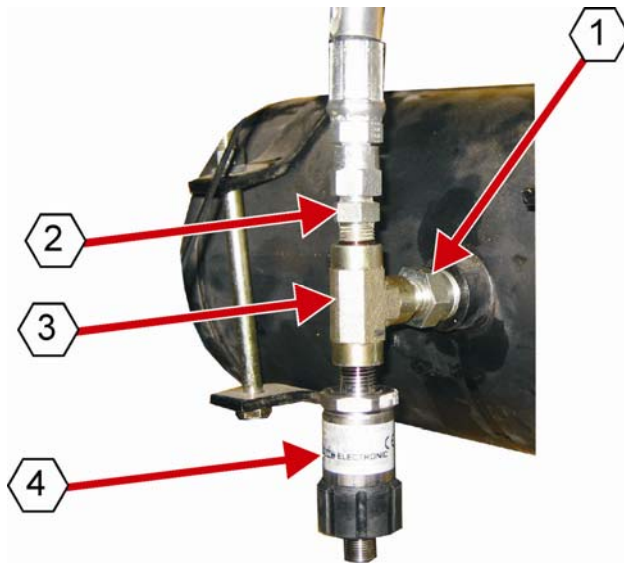

Tee and fittings on side of Klenz tank

- 1 – 407-6887 8 MP X 4 MP straight nipple
- 2 -- 052-7116 4 MP X 6 MJ adapter
- 3 -- 403-1446 4 FP X 4 FP X 4 FP tee
- 4 -- 425-5489 0-200 psi transducer (This transducer is part of the 425-5494 transducer kit which includes a 425-5449 crossover adapter cable)

19. Install the middle connection of a 403-1446 4 FP X 4 FP X 4 FP tee onto the nipple in side of the Klenz tank
20. Install the 425-5489 0-200 psi transducer into one end of the tee
21. Install an 052-7116 4 MP X 6 MJ adapter into the other end of the tee
22. Remove the Klenz tank inlet (1/16") and outlet (1/8") orifices and verify that they are the correct size and are free of corrosion.

NOTE

The orifices are a critical part of isolating the normal KLENZ system pressure fluctuations from the distribution tank and brake tanks. These orifices must be used and must be in the correct locations for the system to function as designed.

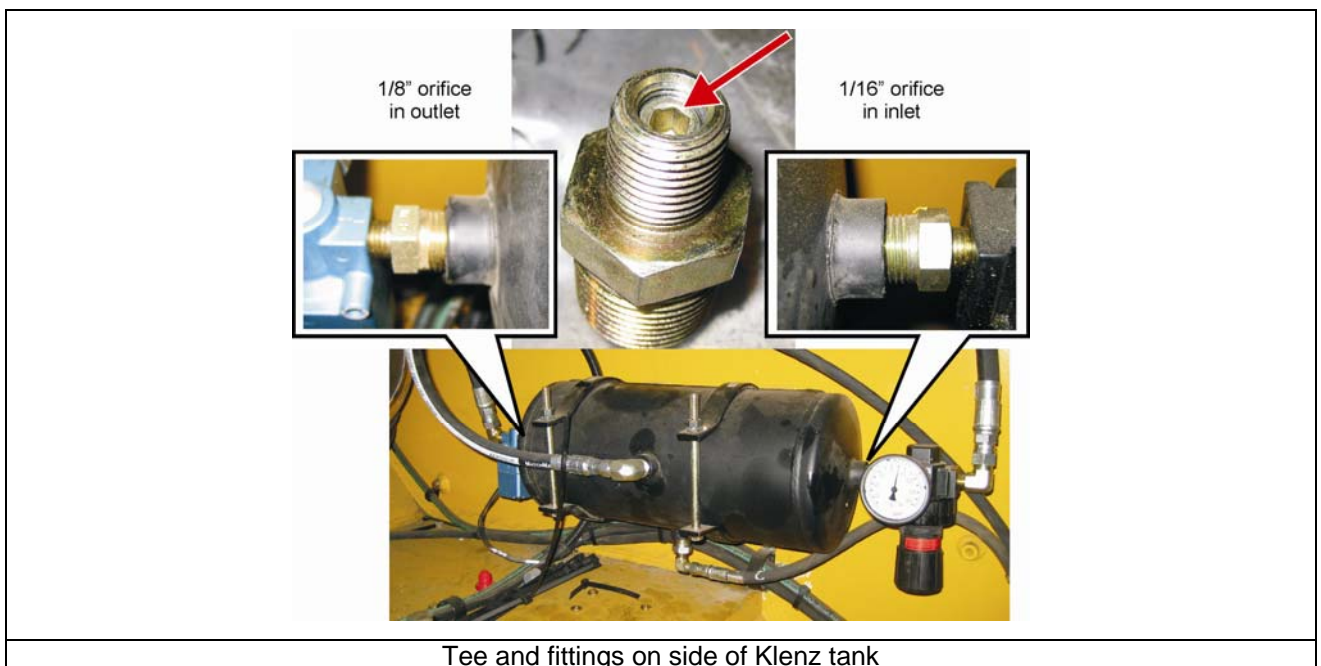

- a. Remove the 425-6313 fitting assembly on the inlet to the KLENZ tank and verify that there is a 1/16" (.062"/1.6 mm) orifice installed. Clean the orifice if required.

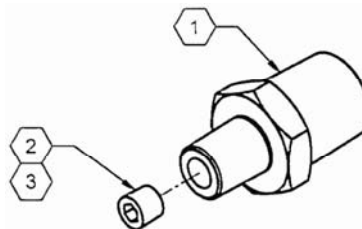

425-6313 Fitting assembly (*This P/N included for reference only. This fitting is not included in the kit.*)

- 1 --- 425-6311 Fitting 8 MP X 4 MP with 1/16 NPT tapped
- 2 --- 413-6495 Orifice - .062 drilled hole in 1/16 NPT plug
- 3 --- 410-3739 Loctite Hydraulic Sealant

- b. Remove the 425-6312 fitting on the outlet of the KLENZ tank and verify that there is a 1/8" (.125"/3.2 mm) orifice. Clean the orifice if required.

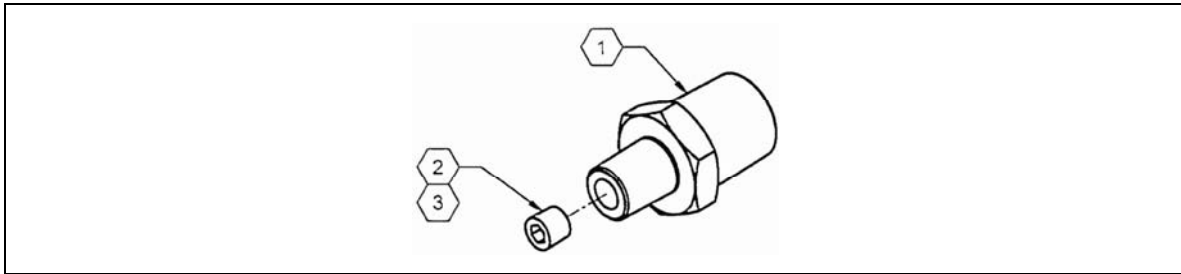

425-6312 Fitting assembly (This P/N included for reference only. This fitting is not included in the kit.)

- 1 --- 425-6311 Fitting 8 MP X 4 MP with 1/16 NPT tapped
- 2 --- 413-6497 Orifice - .125 drilled hole in 1/16 NPT plug
- 3 --- 410-3739 Loctite Hydraulic Sealant

23. Install a 082-8313 check valve on the inlet of the KLENZ tank air regulator.

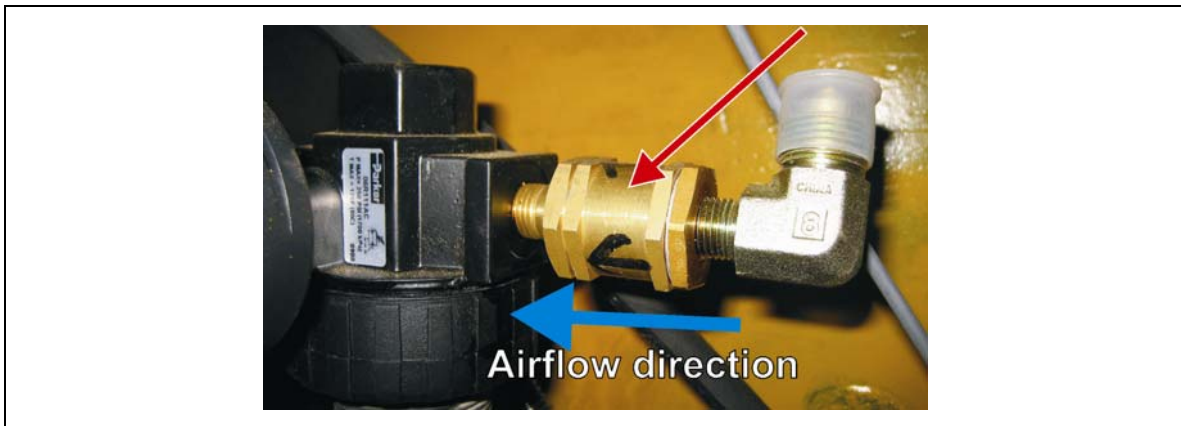

Check valve on inlet of Klenz air regulator

24. Remove the hydraulic tank supply hose from the distribution reservoir (hose between tank and solenoid).
- a. Remove the existing 6 MP X 6 MJ adapter.
 - b. Install a 401-3780 6 MP plug. (401-3779 4 MP plug, 401-3780 8 MP plug and various JIC caps and plugs are also included in case they are required)
25. Connect the hydraulic tank supply line to the fitting on the side of the KLENZ tank.
- a. This may or may not require a new hose depending on the location of the KLENZ tank and distribution tank.
 - b. A 403-0310 #6 X 92" hose is included in parts list for the 1850 and 950.
 - c. A 415-3297 #6 X 140" hose is included in parts list for the 1350.
26. Remove the existing air regulator for the hydraulic tank.

NOTE

Note that the mounting bracket used on the old air regulator will not fit the new regulator.

27. Install the new 426-4840 0-15 psi hydraulic tank air regulator.

NOTE

The new regulator may be either a Parker 0-15 psi regulator (yellow adjustment knob) or a Norgren 0-10 psi regulator (black adjustment knob). Both are equivalent and acceptable for this application.



0-15 psi Parker



0-10 psi Norgren

Air regulator types

- a. The regulator must be installed with the correct direction of airflow. There is a small arrow indicating the direction of air flow through the regulator. The air will flow from the solenoid through the regulator and to the hydraulic tank.

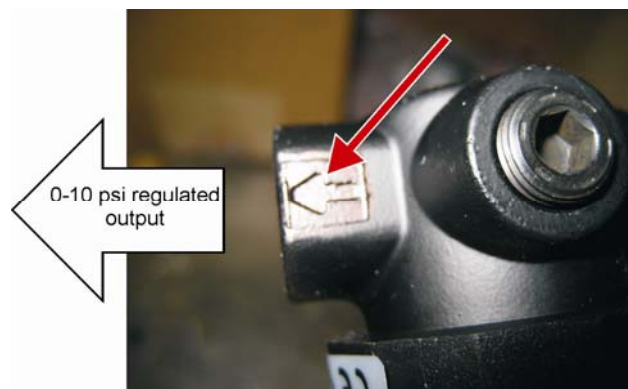

Air regulator installation orientation

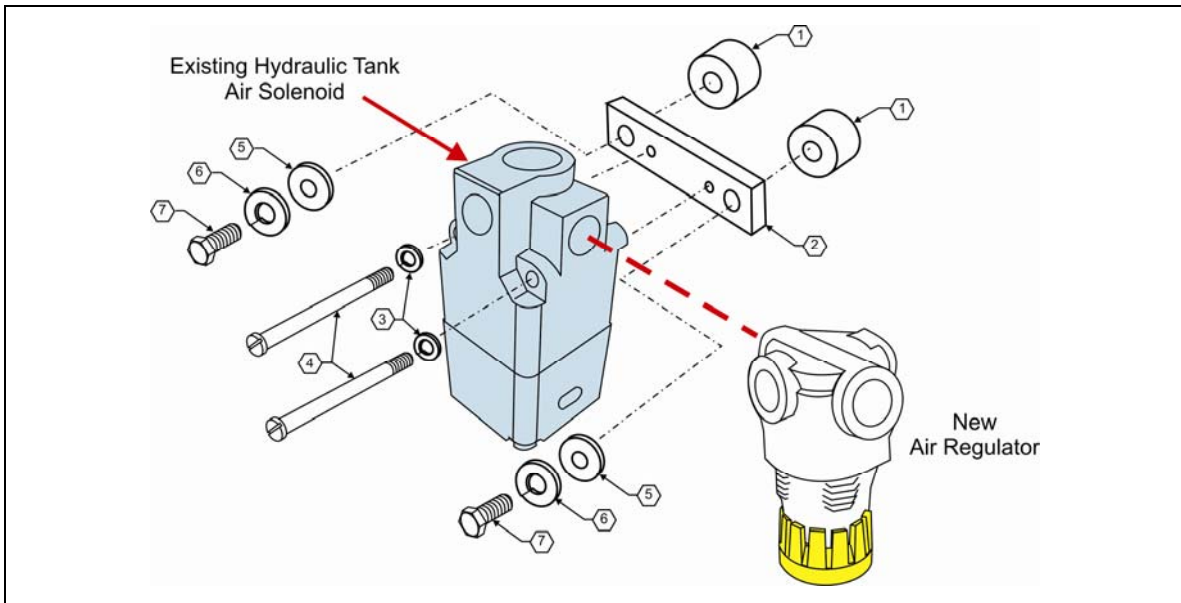

Install the air solenoid mount bar on the existing hydraulic tank solenoid
 1 --- 401-0290 ¼ X ½ Bolt block
 2 --- 425-7638 Solenoid bar mount
 3 --- 401-0907 Lockwasher

4 --- 006-0043 Machine screw
 5 --- 401-0923 ¼ flat washer
 6 --- 021-3584 ¼ lock washer
 7 --- 081-0986 ¼ X ¾ Bolt

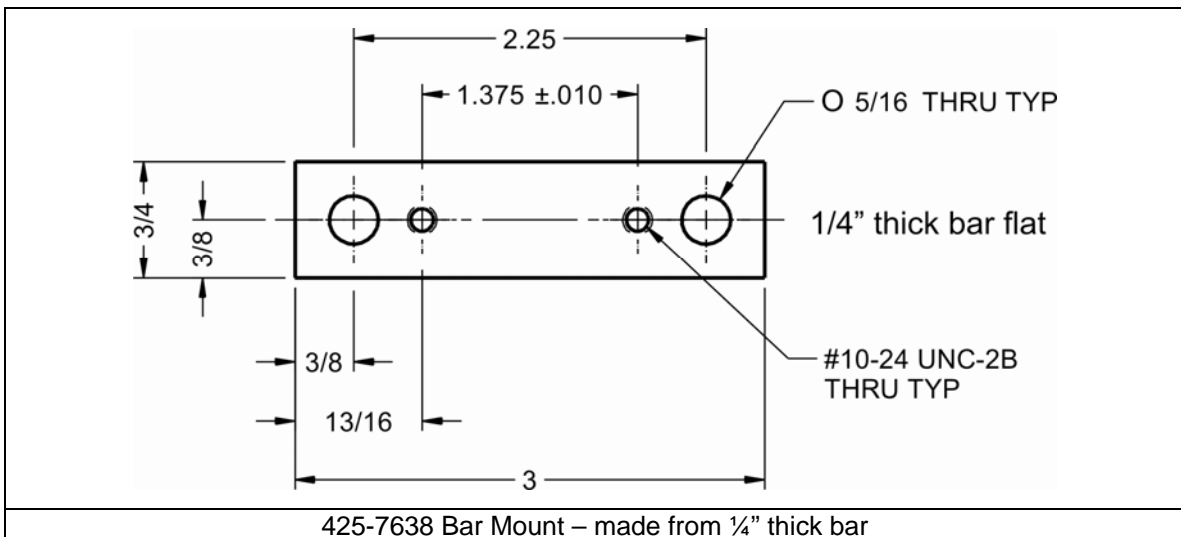

- b. Mount the 401-0290 bolt blocks onto the 425-7638 solenoid bar mount.
- c. Tack weld the bolt blocks in place. (You may be able to use one of the existing bolt blocks)
- d. Remove the 425-7638 bar mount.
- e. Weld out the bolt blocks.
- f. Paint the bolt blocks and the bar mount if required.
- g. Connect the 426-4840 air regulator to the solenoid valve using the original 4 MP straight nipple fittings

- h. Mount the solenoid/regulator assembly onto the bar mount using the 006-0043 machine screws and 401-0907 lock washers.
- i. Install the new style 425-6397 12 psi check valve.
- j. Connect all hoses.

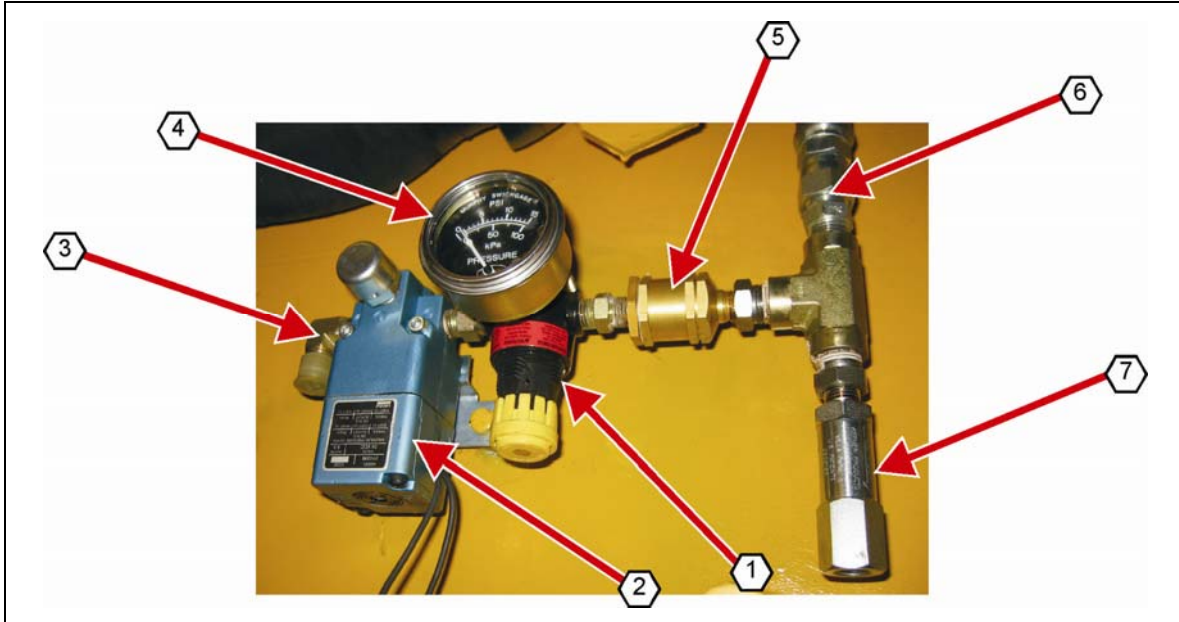

1. 426-4840 Air Regulator 0-15 psi
2. 403-9803 Existing Air Solenoid (reference only – not in kit)
3. Air inlet from the KLENZ tank
4. 406-7043 Existing Pressure Gauge (reference only – not in kit)
5. 082-8313 Existing Check Valve (reference only – not in kit)
6. Existing Line to hydraulic tank (reference only – not in kit)
7. 425-6397 12 psi check valve

28. Remove the 0-50 psi hydraulic tank pressure transducer – normally mounted at the top of the transducer manifold on the **HT** (hydraulic tank) position.
29. Install the 426-5196 0-15 psi hydraulic tank pressure transducer in the same position.

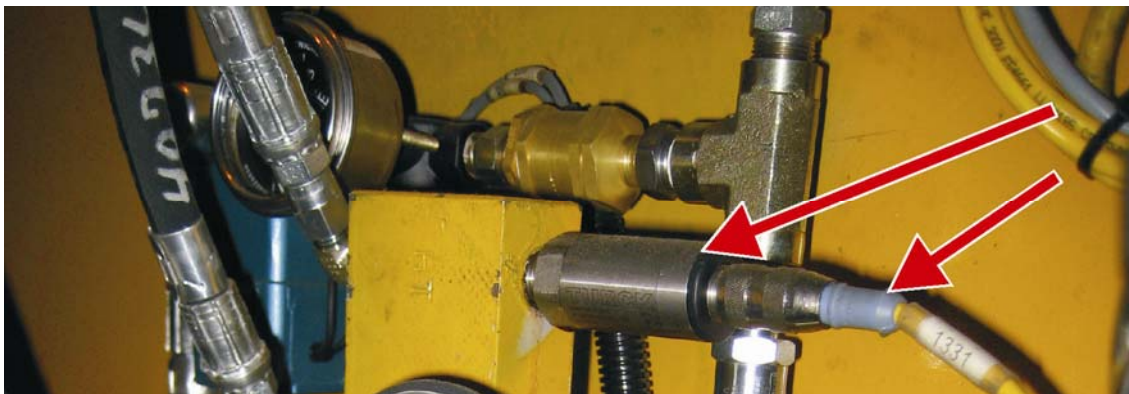

Install the new 0-15 psi pressure transducer – note special cable with blue strain relief

The new transducer has a 4 pin EURO type connection. There are various types and brands of transducers and cables in use. Most previous transducers used DIN type connectors. Pins 2 and 3 are swapped between the DIN and Euro connectors and a special crossover cable with blue colored strain reliefs is used. See the following information to determine what is needed for your machine.

Model	Wire #	Location	Notes
Non Turck wired machine			
L1350 #1-15		Pressure manifold HT position	<ul style="list-style-type: none"> Remove the DIN connector from the cable Install the 425-1784 connector on the existing cable Connect the 425-5449 Euro to Euro crossover (blue strain reliefs) between the connector and the pressure transducer
1850 #1-15			
Turck wired machine with DIN connector			
L950 L1350 L1850 L2350			<ul style="list-style-type: none"> Remove the DIN cable between the transducer and the Turck box Connect the 425-5449 Euro to Euro crossover (blue strain reliefs) between the Turck box and the pressure transducer
Turck wired machine with EURO connector			
L950 L1350 L1850 L2350			<ul style="list-style-type: none"> Connect the existing cable to the new pressure transducer.

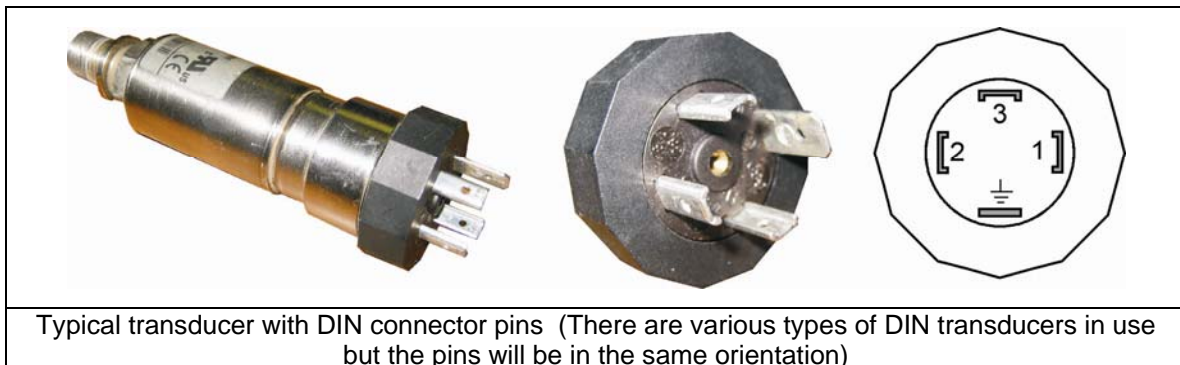

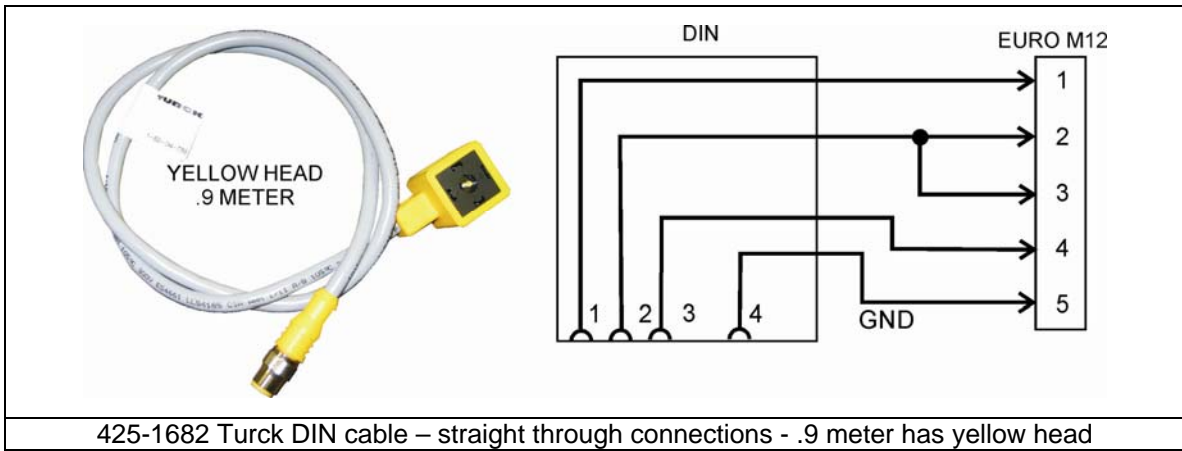
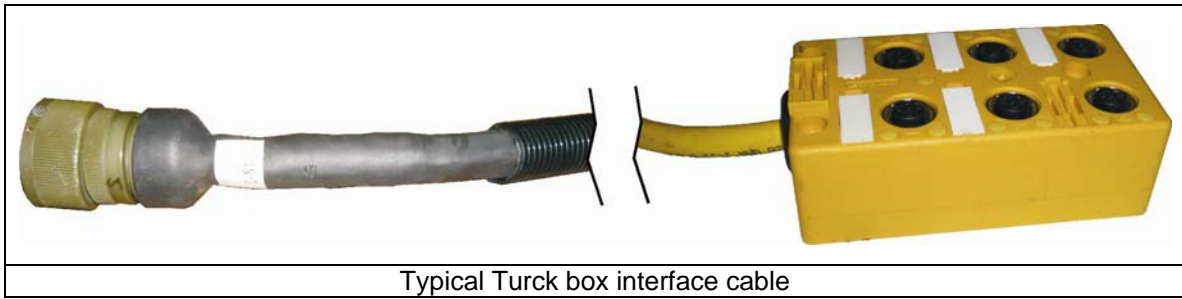
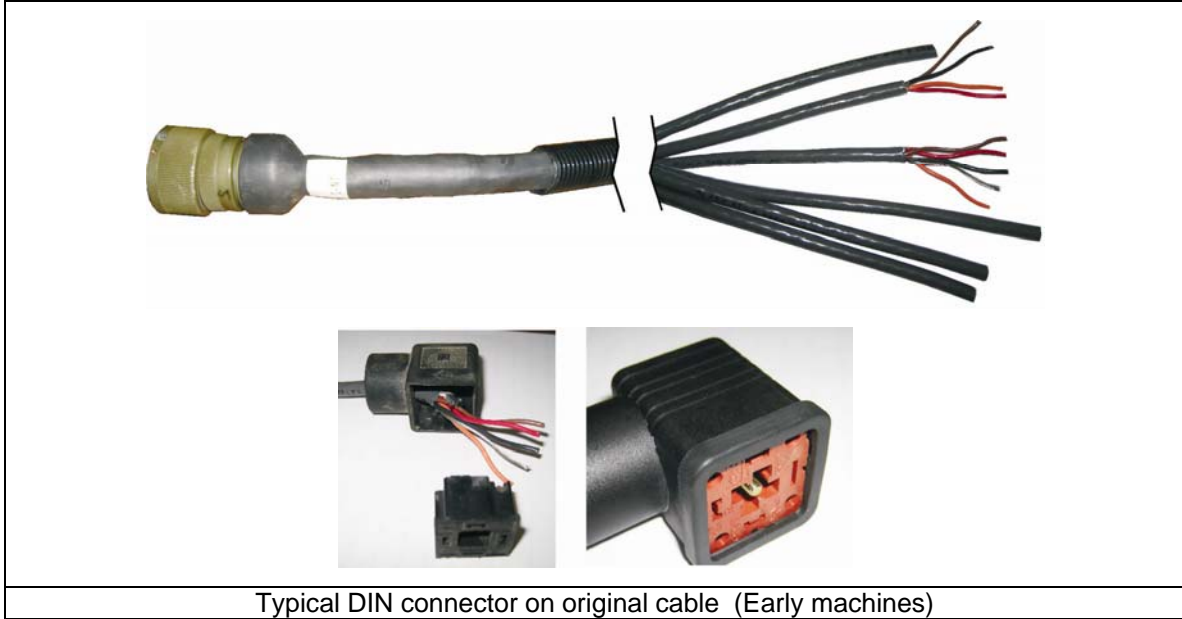

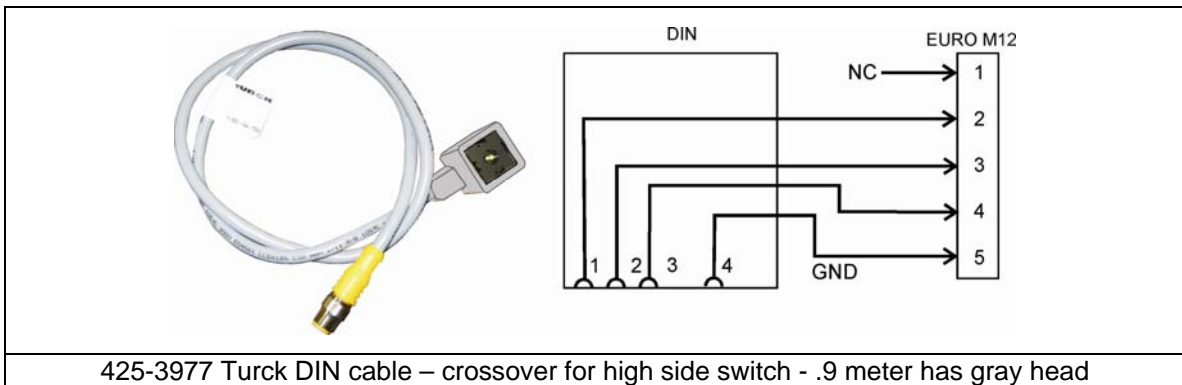
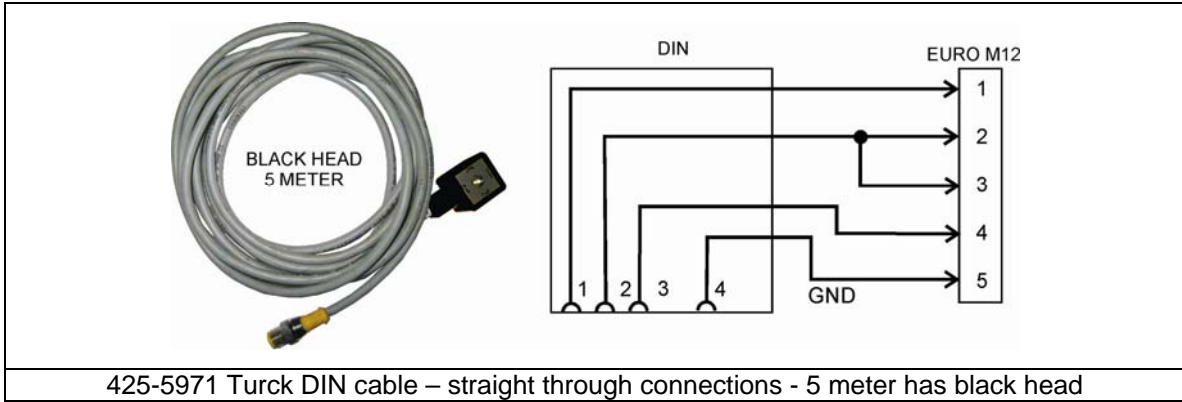

NOTE

The information on the GRAY colored DIN head cable is only provided here for reference purposes. The cable with the gray DIN head is NOT USED with pressure transducers – only for high side switch applications.

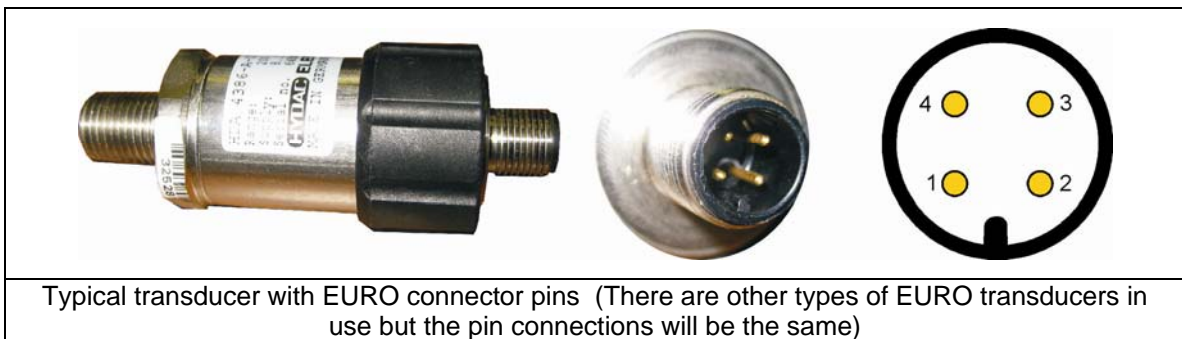

Crossover cable 425-5449 .9 meter required with EURO type transducer (identified by blue strain relief)

Straight through EURO extension cable
 425-1781 2 meter (not in kit – for reference only)
 426-0402 4 meter (not in kit – for reference only)
 425-1687 10 meter

425-1784 EURO female adapter for open cable – connects to EURO transducer

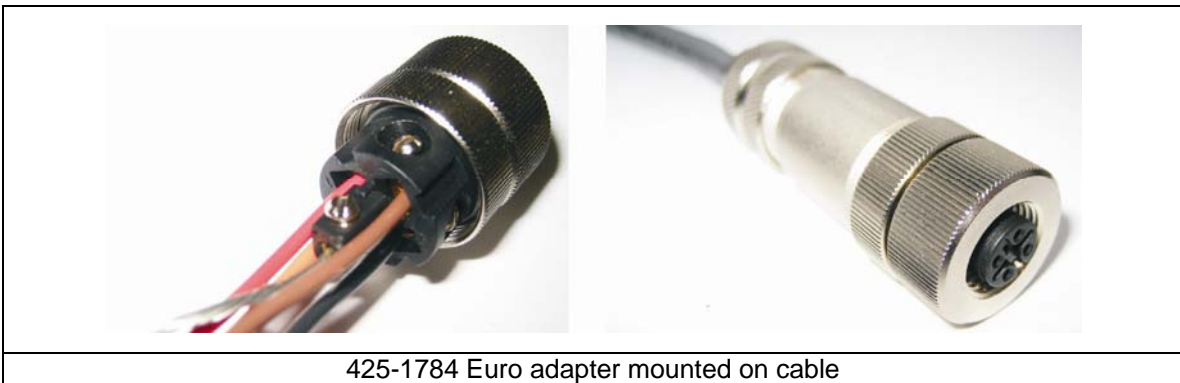
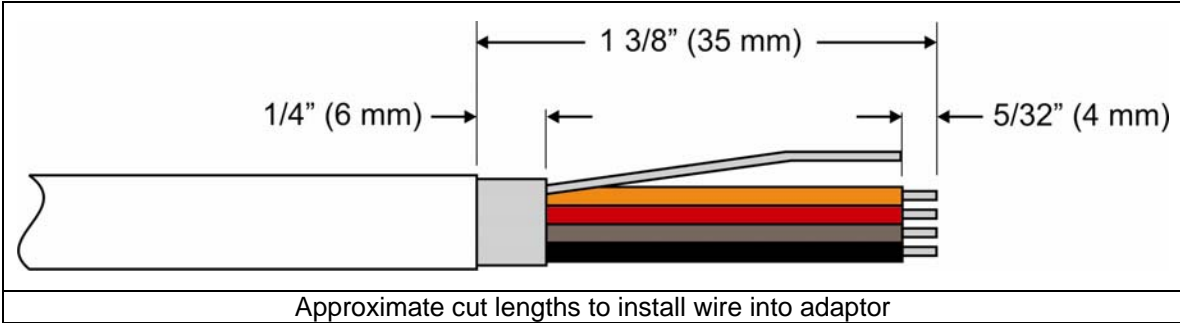

30. Disconnect the #4 hose between the air governor and the air compressor unloader port

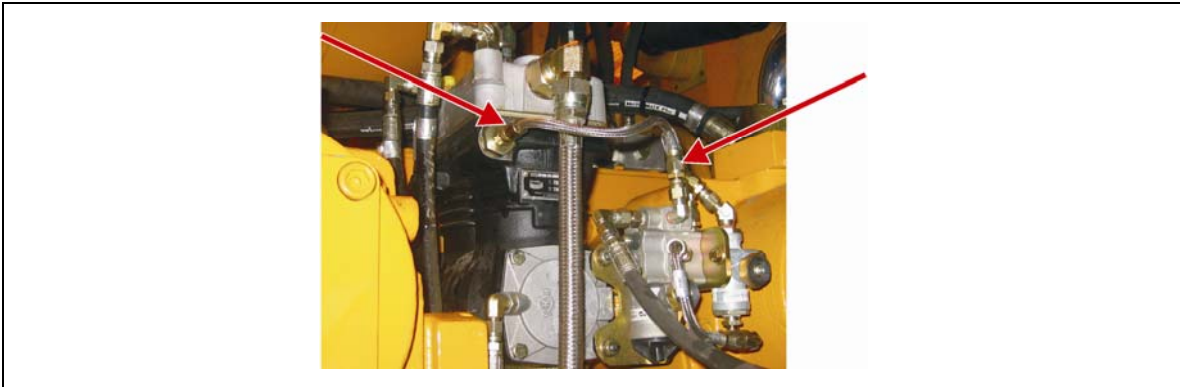

Disconnect hose to compressor unloader

31. Install the 425-8827 #4 FJ swivel X 1/8 FP fitting onto the JIC fitting in the unloader port of the air compressor.

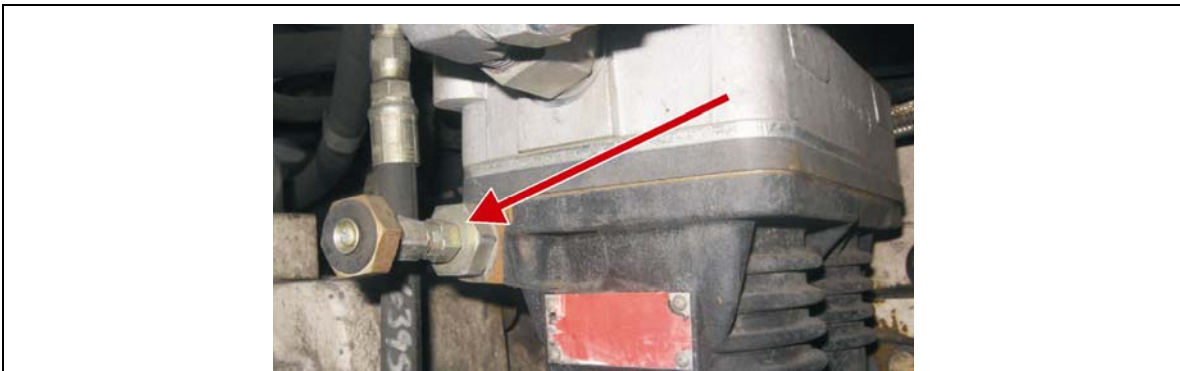

Install breather into unloader port

NOTE

The 424-4688 fitting should already be installed in the unloader port of the 596 compressor. This is a metric/USA fitting that is often difficult to source. A spare fitting is included in this kit. This information included for reference purposes only.

32. Install a 424-4790 breather into the 1/8 FP fitting

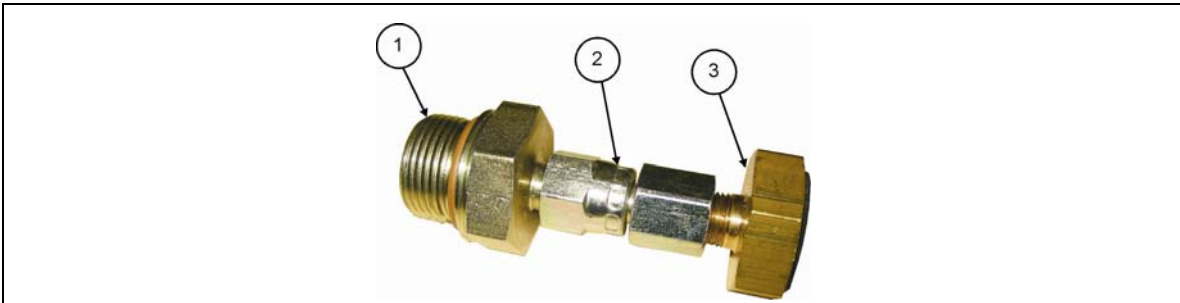

Install breather onto the unloader port

- 1 --- 424-4688 Adapter M22 X 4MJ
- 2 --- 425-8827 Adapter 4 FJ swivel X 1/8 FP
- 3 --- 424-4790 Breather check valve

33. Disconnect and remove the syncro valve.

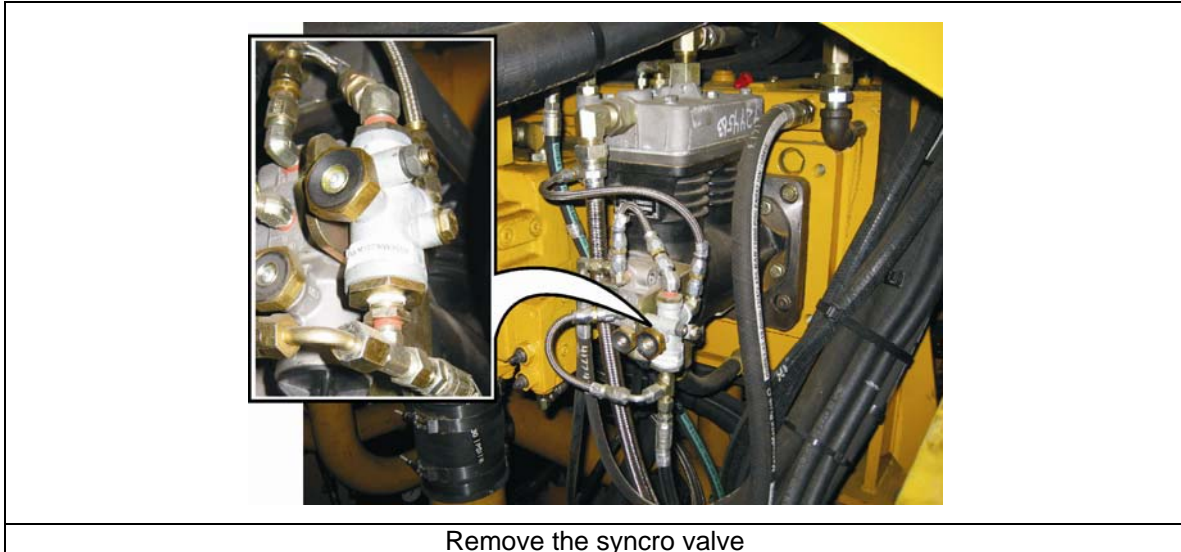

34. Install 071-6331 1/8" NPT socket plugs in unused ports on the governor.
35. Connect the hoses for pressure sense (distribution tank) and unloader (to the air dryer). There should only be two hoses to the governor when the updates are completed.
- a. One pressure sense hose from the distribution tank
 - b. One unloader hose going to the air dryer unloading port.

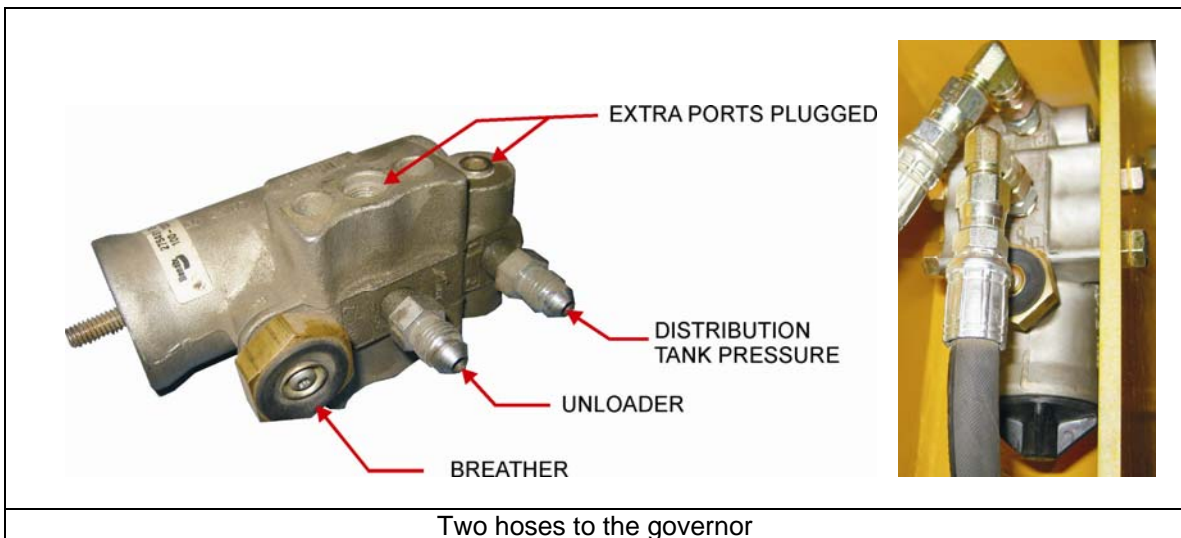

36. Connect the 425-5449 TURCK crossover adapter cable (blue strain reliefs) to the 425-5489 0-200 psi pressure transducer previously installed on the KLENZ tank.

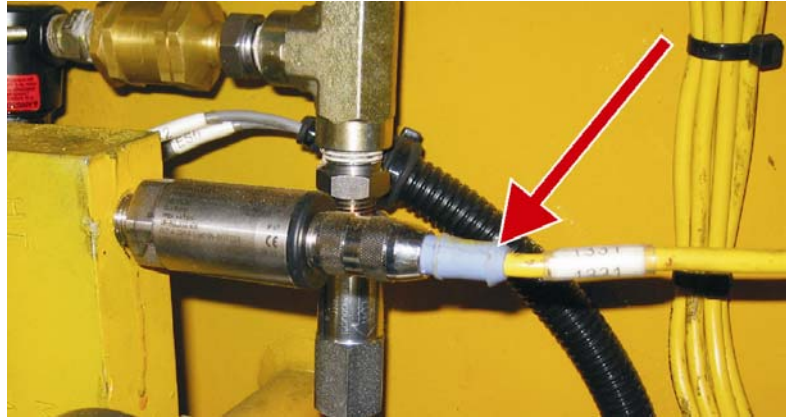

Crossover cable connected
(Note the blue colored strain relief that identifies the special crossover cable)

37. Connect the 425-1687 TURCK extension cable to the crossover cable.
38. Route the KLENZ pressure transducer wiring to wire #153X as shown in the following table.

NOTE

The channels specified in the following table were correct to the best of our knowledge at the time of the writing of this document. It is possible that this channel might vary depending on options installed on a given machine. If you find that the channel specified in the following table is already occupied on your machine – contact LTI Product Support for further help.

Model	Wire #	Location	Notes
Non Turck wired machine			
L1350 # 1-6, 8	#1533		
L1350 #7, 9- 15	#1532		<ul style="list-style-type: none"> • Move "Aux Oil Cooler Fan Sol" on L1350 #10 to #1323
1850 #1-15	#1521	Engine Pilot Solenoid	<ul style="list-style-type: none"> • This Wire # is typically connected to "Engine Pilot Sol #3L" signal • This was connected to monitor the Pilot Sol voltage but is not used by the configuration. • Disconnect the wire • Install the 425-1784 Euro adapter on the cable • Connect the 425-1687 extension cable to the Euro adapter • Connect the extension cable to the 425-5449 TURCK crossover cable.
Turck wired machine			
L1850 L2350	#1531	Underneath engine translator module	<ul style="list-style-type: none"> • This Wire # is typically connected to "Engine Pilot Sol #3L" signal • This was connected to monitor the Pilot Sol voltage but is not used by the configuration. • Disconnect the wires from Engine Pilot Sol • Connect the 425-1687 extension cable to the 425-5449 TURCK crossover adapter cable
L1350 #16 and up	#1535	Lower corner of 24V electrical cabinet	<ul style="list-style-type: none"> • Disconnect the Turck cable from 1535. This cable goes to the 75H wire that supplies power to the spitter valves. • Run the Turck extension cable into the 24V cabinet with one of the wire bundles.
L950	#1535	Lower corner of 24V electrical cabinet	<ul style="list-style-type: none"> • Disconnect the Turck cable from 1535 and the DIN rail. This cable goes to the 75H wire that supplies power to the spitter valves. On most machines it was there to monitor the 24V to the spitter valves and is no longer required since the spitter valves have been removed. • Remove "Hoist Cylinder Rod Pressure" from L950 #2002 • Carefully route the Turck extension cable into the 24V cabinet with one of the wire bundles. This will require a fish tape and wire pulling lubrication to assure that the fish tape and new cable does not damage existing cables

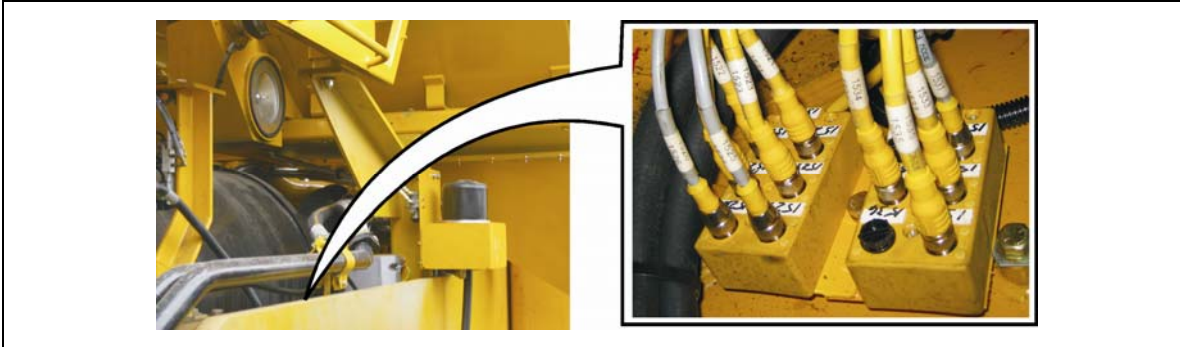

Typical Turck box location on 1350 1-15, 1850 and 2350
(on frame in area under engine translator)

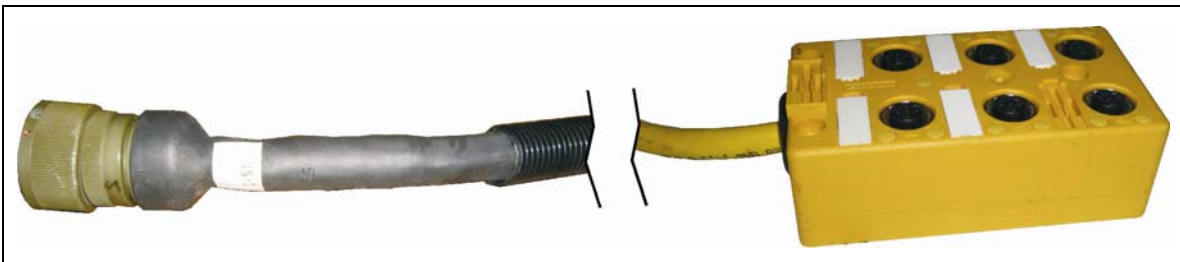

Typical Turck box interface cable

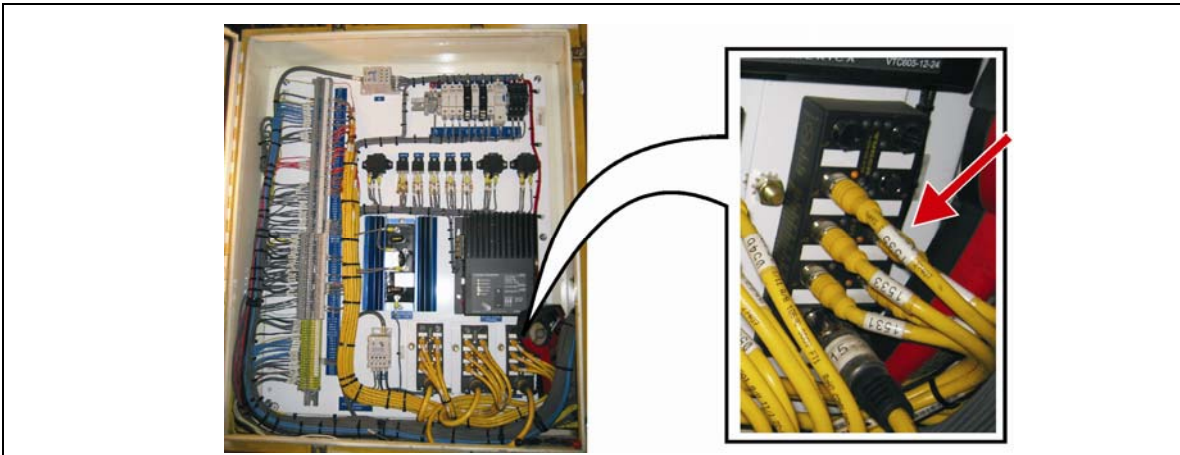

Turck box location in 1350 #16 and up and 950 (lower right corner of 24V cabinet)

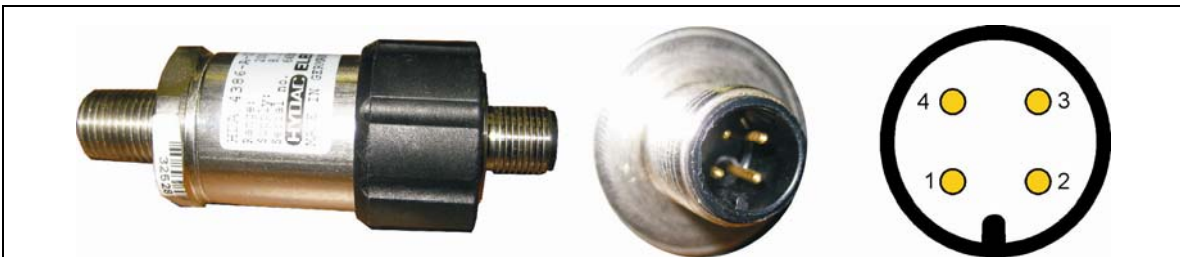

Typical transducer with EURO connector pins (There are other types of EURO transducers in use but the pin connections will be the same)

NOTE

The transducer comes with a special crossover adapter cable that can be identified by the blue colored strain reliefs as shown in the following figure.



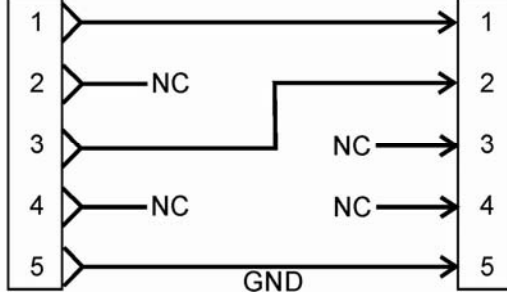

Crossover cable 425-5449 .9 meter required with EURO type transducer (identified by blue boot)





Straight through EURO extension cable
 425-1781 2 meter (not in kit – for reference only)
 426-0402 4 meter (not in kit – for reference only)
 425-1687 10 meter

39. Verify that the pressure relief valves on the distribution and front frame and rear frame air tanks are 175 psi. Replace if they are not. (one 425-5667 175 psi relief valve is included in the kit)

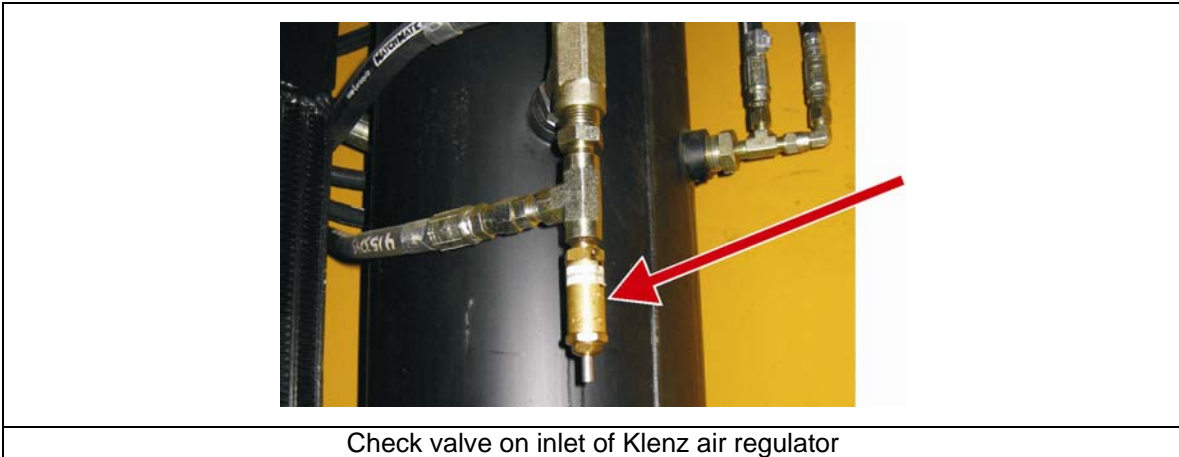

40. Install the 425-8483 DLU purge valve into the dryer

CAUTION

If the purge valve is being removed with the dryer in place on the machine – drain all air from the system prior to removing the purge valve. The purge valve can come out with dangerous force if the snap ring is removed while there is air pressure on the dryer.

- a. Remove the black exhaust port 425-8491

NOTE

Some air dryers do not have the exhaust port installed. This port must be installed later in the procedure. It will be necessary to tap the screw holes with the 10-24 tap to get the screws to fit properly.

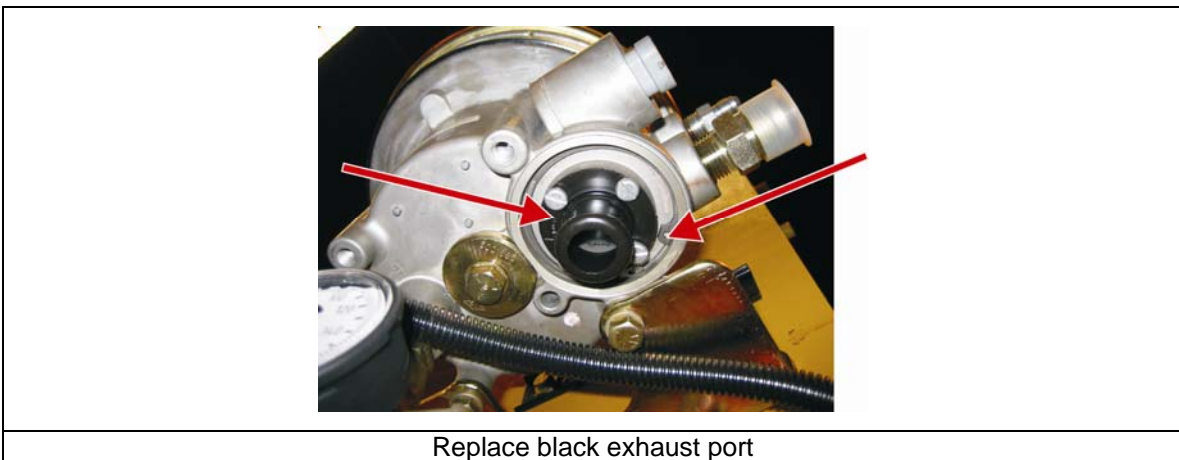

- b. Remove the snap ring

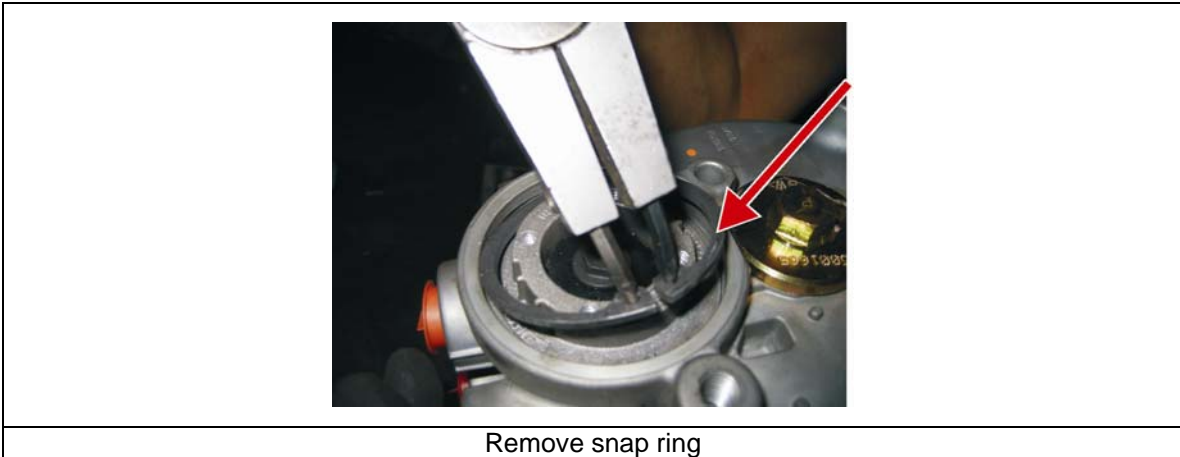

- c. Remove the old purge valve



- d. Verify that the new DLU purge valve has a silver colored stainless steel spring. Install the 426-1581 spring if required.

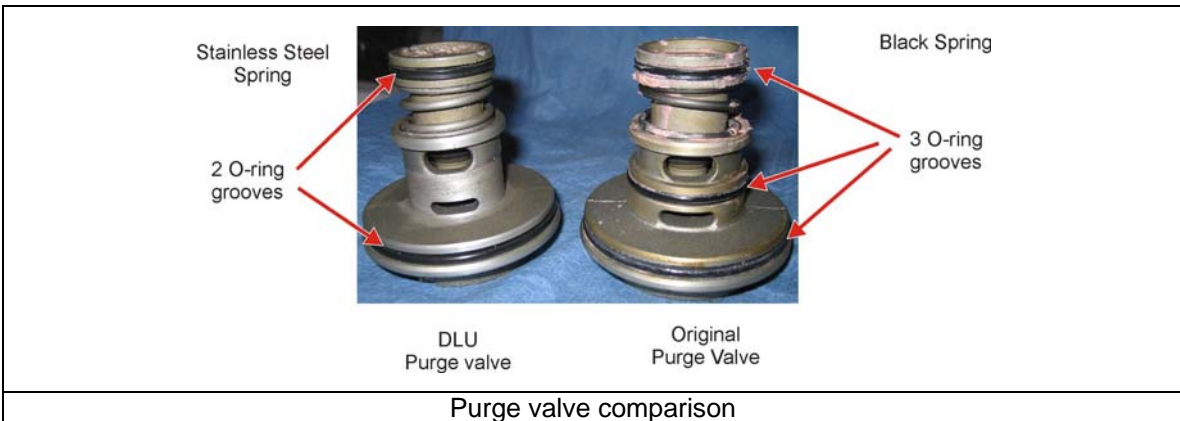

- e. The purge valve typically arrives with a small tube of Bendix silicone grease. Lubricate the O-rings on the purge valve with the included grease. If the Bendix

grease is not present – lube the O-rings with a silicone grease such as 425-6386 silicone lubricant (Specialty Silicone Products SSP-1201-A)

- f. In particular verify that the small seal is in good shape and lubricated.
- g. Use care and caution when installing the DLU purge valve into the dryer housing. This is a tight fit and seal damage can occur if not installed properly.
- h. If the purge valve does not go into the dryer housing easily by hand – removing, lubricating and reseating the seal may help.

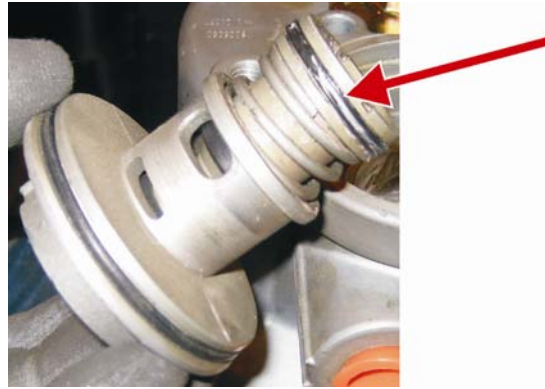

Purge valve seal

- i. Install the new purge valve. Push into place. DO NOT use a hammer to install.

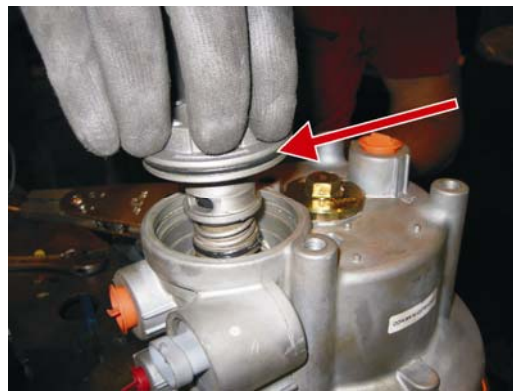

Install new purge valve

- j. Install the snap ring
- k. Install the black exhaust port

NOTE

If the exhaust port is being installed for the first time, it will be necessary to tap the screw holes using the 10-24 tap and securing with the #10-24 x 5/16" screw and #10 lock washer (tap, screws and lock washers are provided in the kit).

41. Install the 425-8493 60" exhaust hose on the dryer exhaust.



Install exhaust hose

- a. Install the 051-9707 2" SS clamp to hold the hose in place.
42. Close all air valves
43. Install software
- a. Capture a restore point from the machine
 - b. Install the new software
44. Apply 110-135 psi shop air to the distribution tank and inspect the machine for air leaks
45. Boot LINCS (do not start engine at this time).
- a. Find the channels for hydraulic tank air pressure and KLENZ tank air pressure in LINCS and verify the two pressure transducers are functioning properly and reading correct pressures
 1. If they do not appear to be connected – look at Enhanced Channel Browser for each channel and verify that the channel number is the same as what the Turck cables were connected to.

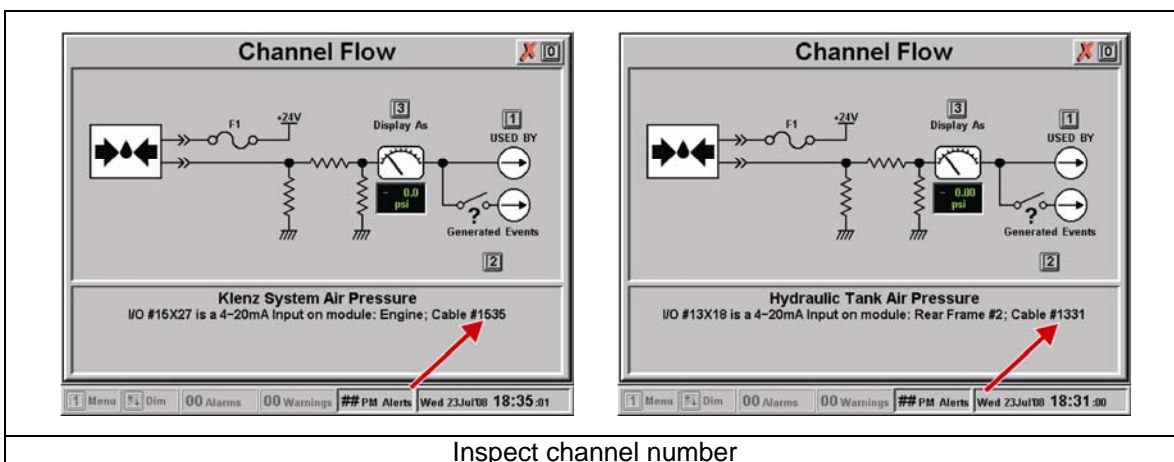

- b. Use an ultrasonic leak detector to inspect machine for leaks in the hydraulic tank and the KLENZ diaphragm valves.



Protect your ears with appropriate protection when opening the KLENZ box. Unless the solenoids are disabled in LINCS it is possible that they might fire. It is also possible to dislodge one of the solenoid sense hoses and cause the diaphragm valves to fire. The shock wave that occurs at the time a valve fires can cause ear damage if you were too close.

46. Set the air pressure with the governor.
 - On machines with Bendix brake canisters (black) set the air pressure as read in LINCS (from distribution tank) to 120-135 psi. Note that the pressure gauge at the dryer will typically read 5-10 psi higher.
 - On machines with the large LeTourneau brake canisters (silver) set the air pressure as read in LINCS (from distribution tank) to 135 psi. Note that the pressure gauge at the dryer will typically read 5-10 psi higher.
 - Cycle the air system and look at the high and low pressures. The range from low to high (compressor off and on) as controlled by the governor should be no more than 20 psi. If the pressure range between high and low is erratic or larger than 20 psi then the governor should be cleaned, rebuilt or replaced.

Section 5:
INSTALLATION
CHECK LIST

Blank on purpose for double sided printing

Installation Check list

Item	Description	Complete
1	Remove air filter on the inlet air <ul style="list-style-type: none"> • Leave the MP X MJ adapter fitting in the side of the air duct • Connect the hose to the fitting. (This only applies to some machines)	
2	Remove the air cooler in the air duct ((This only applies to some machines) The compressor inlet air should come from a fitting in the side of air duct to front axle	
3	Remove receiver tank	
4	Remove hose between compressor and receiver tank	
5	Remove the hose between the receiver tank and the air dryer	
6	Install Stainless Steel hose	
7	Remove automatic drain (spitter) valve from rear frame reservoir and install plug	
8	Remove automatic drain (spitter) valve from distribution reservoir and install plug	
9	Remove automatic drain (spitter) valve from front frame reservoir and install plug	
10	Disconnect the 75D, 75E, 75F, 75G power wires for automatic drain (spitter) valves	
11	Remove the bushing and air valve from the bottom of the Klenz tank	
12	Install a 8 MP X 4 FP bushing into bottom of Klenz tank	
13	Install a ¼ MP X #4 MJ adapter fitting into bushing.	
14	Route air bleed hose from bottom of the Klenz tank to the second air bleed valve	
15	Connect the air bleed hose for the distribution tank onto the first air bleed valve	
16	Install air bleed hose and valve for front frame tank	
17	Remove the plug in the side of the Klenz tank	
18	Install a 8 MP X 4 MP nipple adapter in side of the Klenz tank	
19	Install the middle connection of a FP X FP X FP tee onto the adapter in side of the Klenz tank	
20	Install the 0-200 psi transducer into one end of the tee	
21	Install a 4 MP X #6 MJ adapter into the other end of the tee	
22	Remove the fitting on the inlet and outlet to the KLENZ tank and verify that there is a 1/16" (.062"/1.6 mm) orifice on inlet and 1/8" (.125"/3.2 mm) on outlet.	
23	Install a check valve on the inlet of the KLENZ tank	
24	Remove the hydraulic tank supply hose from the distribution reservoir (hose between tank and solenoid) <ul style="list-style-type: none"> • Remove the 3/8 MP X #4 MJ adapter • Install a 3/8 MP plug 	
25	Connect the hydraulic tank supply line to the fitting on the side of the KLENZ tank	

Section 6:

AIR SYSTEM

MAINTENANCE:

Blank on purpose for double sided printing

Air system maintenance:

Once the air system has been updated it is important to perform regular maintenance on the air system. Please add the following to your normal maintenance program.

Daily:	<ul style="list-style-type: none"> Repair air leaks and problems as indicated by LINCS alarms and messages
500 hour	<ul style="list-style-type: none"> Apply shop air to the distribution tank (115-135 psi) Check air system (distribution tank, brake tanks, brakes, KLENZ tanks) for leaks with ultrasonic leak detector Boot LINCS Check KLENZ diaphragm valves for air leaks Check the KLENZ solenoids and hosing for air leaks with ultrasonic leak detector Check Hydraulic tank for air leaks with ultrasonic leak detector Drain air from hydraulic tank and verify the air pressure regulator setting. <p>Air Bleed down test Remove shop air Start engine and build air pressure Stop engine and monitor air pressure. (refer to troubleshooting sections for more details)</p>
1000 hour	<ul style="list-style-type: none"> Change air dryer desiccant cartridge
2500 hour	<ul style="list-style-type: none"> Change DLU purge valve in Dryer Replace the diaphragm kits in the KLENZ diaphragm valves

- **Use an ultrasonic air leak tester** to test the system for air leaks during normal maintenance intervals. This has been factory and field tested and has been proven to make air leak detection very quick and accurate. There are many models of ultrasonic leak detectors available. The factory has used an Inficon Whisper[™] that is low cost but works very well for detecting air leaks. This is available from LTI under LTI P/N 426-4953 and local distributors as Inficon P/N 711-202-G1.



P/N 426-4953 Ultrasonic leak detector

- **Maintain the system to minimize air leaks** that increase the duty cycle of the compressor. The only time the dryer purges is when the governor setting is reached. The dryer must remain in the purge cycle for a minimum of 30 sec to effectively dry the desiccant.

NOTE

LINCS must be booted up for air leak inspections so the solenoids will be open and air will be on the hydraulic tank and KLENZ

! CAUTION

Protect your ears with appropriate protection when opening the KLENZ box. Unless the solenoids are disabled in LINCS it is possible that they might fire. It is also possible to dislodge one of the solenoid sense hoses and cause the diaphragm valves to fire. The shock wave that occurs at the time a valve fires can cause ear damage if you were too close.

Following are some of the key areas that should be checked:

- **Klenz diaphragm valves inspection and scheduled changeout**
 - Scheduled changeout
 - The Klenz valves should be changed or rebuilt at 2500 hour intervals.
 - This is an approximate number and can vary depending on many factors such as temperature, cycle time, etc.
- **Maintenance**
 - Two types of diaphragm valves have been used. The original was a square type and the latest (recommended) is a round diaphragm valve.

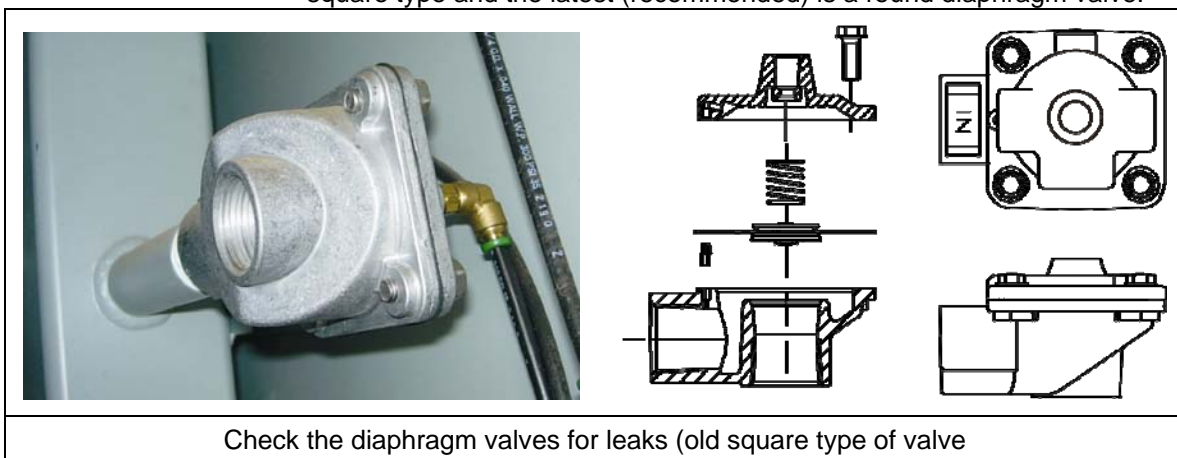

- 421-9823 Diaphragm valve (if you order this it will be replaced by 425-5196 or 425-9367 – round type)
- 423-4073 Diaphragm repair kit
- The round diaphragm valve shown is the recommended valve for all applications as it uses less air and provides a stronger shock to the

filters. It is recommended to use this valve as a replacement for the previous square valves

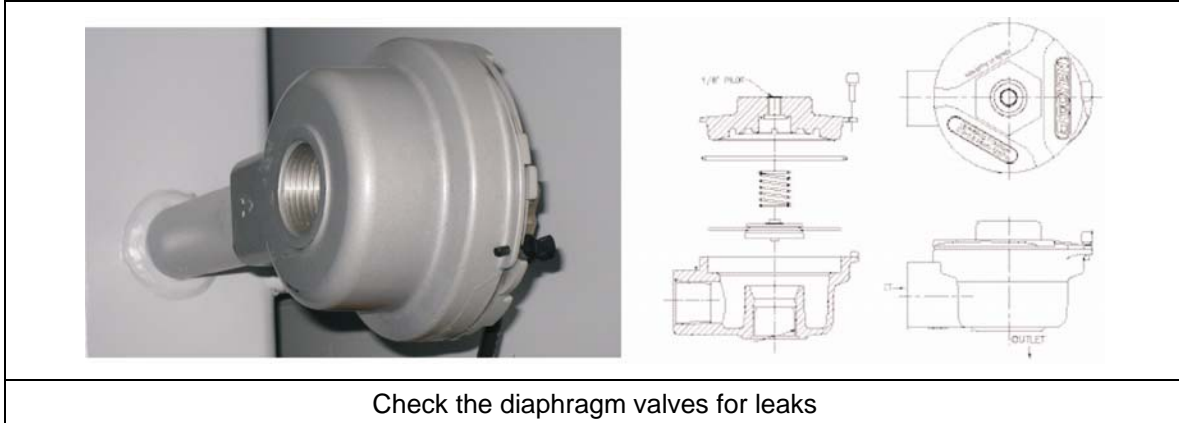

Check the diaphragm valves for leaks

- 425-5196 Round diaphragm valve (same component is 425-9367)
- 425-9368 Repair kit
- **Klenz solenoid box mounting**
 - **The solenoid box should be mounted as shown below so that the solenoid plungers are mounted vertically.**
 - **The plungers can stick if they are mounted horizontally.**
- **Klenz signal hoses**
 - Inspect and make sure that the hoses are intact and not leaking
 - Replace with #4 JIC hoses if needed.

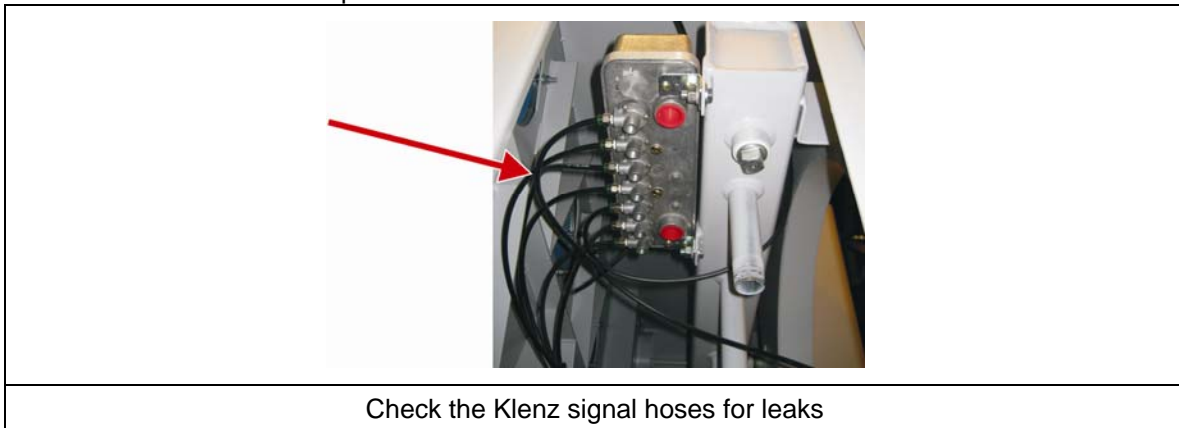

Check the Klenz signal hoses for leaks

- **Hydraulic tank pressure settings and leaks**
 - Refer to the Hydraulic Tank Air Adjustment procedure for details on setting the tank air pressure in the proper manner
 - Inspect the pressure settings to be sure that the air is not coming out of the 12 psi check valve.
- **Monitor for air leaks with pressure bleed down test.**
 - Machine at high throttle with Klenz disabled and not using air brakes or horn
 - The air system should typically drop at a rate less than .5 psi per minute.
 - Any drop over 1 psi per minute indicates a severe air leak which must be identified and corrected.
 - (refer to troubleshooting sections for more details)

Blank on purpose for double sided printing

Section 7:



AIR SYSTEM





TROUBLESHOOTING:





Number	Section Name	Page
1	Air System Messages	79
2	Setting Hydraulic Tank Air Pressure	83
3	Isolating Difficult to Find Air Leak	87



Blank page on purpose for double sided printing

Troubleshooting Air System messages

 <p>A yellow warning message box with a black border and diagonal stripes. The text reads: WARNING Air System Leak Detected. At the bottom, there is a small 'Ack' button and a status bar showing '01 Warnings' and the time 'Mon 11/30/19 11:32:45 AM'.</p>	<p>Monitors:</p> <ul style="list-style-type: none"> Air System Duty Cycle. <p>Alarm:</p> <ul style="list-style-type: none"> If the duty cycle is above 40% (adjustable between 25% and 75% by person with “factory rep” level ibutton) or below 5% an alarm will be generated. The duty cycle is based on a 5 minute average and a 2 minute alarm delay. The alarm is ignored for 10 minutes after the engine is started so that it can survive an empty hydraulic tank. The alarm will repeat every two minutes unless the problem is corrected. <p>Action:</p> <ul style="list-style-type: none"> Repair leak in air system If this is the only alarm – the leak will normally be in the, compressor, dryer, governor, brakes or distribution systems. Refer to troubleshooting sequence at the end of this document for detailed steps on finding the source of the leak
 <p>A yellow warning message box with a black border and diagonal stripes. The text reads: WARNING KLENZ System Air Pressure Low. At the bottom, there is a small 'Ack' button and a status bar showing '01 Warnings' and the time 'Mon 11/30/19 11:32:45 AM'.</p>	<p>Monitors:</p> <ul style="list-style-type: none"> KLENZ Tank Air Pressure <p>Alarm:</p> <ul style="list-style-type: none"> If the KLENZ tank air pressure does not build to 80 psi then LINCS will generate an alarm. This air pressure is ignored for the first 10 minutes after the engine is started <p>Action:</p> <ul style="list-style-type: none"> Repair leak in the KLENZ system Repair leak in the Hydraulic tank Refer to troubleshooting sequence for detailed steps on finding the source of the leak
 <p>Two messages are shown. The top one is a blue notice box with a white border and the text: NOTICE KLENZ Timer Sol 0X Control Misfire. The bottom one is a yellow warning box with a black border and diagonal stripes, with the text: WARNING KLENZ Sol 0X Misfire Fault. Both have 'Ack' buttons and status bars at the bottom.</p>	<p>Monitors:</p> <ul style="list-style-type: none"> KLENZ Tank Air <p>Blue Message:</p> <ul style="list-style-type: none"> If the KLENZ tank air pressure does not drop by 10 psi when a diaphragm valve is triggered then LINCS will generate an alarm. The X in the message below will actually be a number. The number refers to the solenoid number. (1-5 for 950, 1-6 for 1350 and 1-7 for 1850/2350) <p>Yellow Warning:</p> <ul style="list-style-type: none"> If the solenoid misfires 5 times in a row a yellow warning is created by LINCS <p>Action:</p> <ul style="list-style-type: none"> Check the KLENZ solenoid indicated. See if air hose connected Use a meter to see if receiving a ground from LINCS Replace remote module Replace solenoid Repair wiring

 <p>The image shows a yellow warning message box with a black border and diagonal stripes. The text reads: WARNING KLENZ Solenoids Not Working. At the bottom, there is a status bar with icons for 'Help', '00 Alarms', '01 Warnings', and '00 PIP Alarms', along with the date and time 'Mon 11/30/09 11:32:45 AM'.</p>	<p>Monitors:</p> <ul style="list-style-type: none"> • Klenz solenoids <p>Alarm:</p> <ul style="list-style-type: none"> • LINCS generates this alarm if the KLENZ solenoids are not being fired by the software when the machine has KLENZ tank air pressure and KLENZ switch is in ON position. <p>Action:</p> <ul style="list-style-type: none"> • Configuration problem • Install the original configuration • Report problem to factory Product Support Department.
 <p>The image shows a yellow warning message box with a black border and diagonal stripes. The text reads: WARNING KLENZ System Air Pressure Sensor/Cable Fail. At the bottom, there is a status bar with icons for 'Help', '00 Alarms', '01 Warnings', and '00 PIP Alarms', along with the date and time 'Mon 11/30/09 11:32:45 AM'.</p>	<p>Monitors:</p> <ul style="list-style-type: none"> • current from the 4-20 ma transducer on the KLENZ tank <p>Alarm:</p> <ul style="list-style-type: none"> • If the current is below 2 ma or above 22 ma and alarm will be generated <p>Action:</p> <ul style="list-style-type: none"> • Replace transducer • Replace Turck cable • Replace Turck box cable • Replace remote
 <p>The image shows a yellow warning message box with a black border and diagonal stripes. The text reads: WARNING Hydraulic Tank Air Pressure Sensor/Cable Fail. At the bottom, there is a status bar with icons for 'Help', '00 Alarms', '01 Warnings', and '00 PIP Alarms', along with the date and time 'Mon 11/30/09 11:32:45 AM'.</p>	<p>Monitors:</p> <ul style="list-style-type: none"> • Current from the 4-20 ma transducer on the hydraulic tank air pressure at the top of the manifold. <p>Alarm:</p> <ul style="list-style-type: none"> • If the current is below 2 ma or above 22 ma an alarm will be generated <p>Action:</p> <ul style="list-style-type: none"> • Replace transducer • Replace Turck cable • Replace Turck box cable • Replace remote
 <p>The image shows two stacked message boxes. The top one is a yellow warning box with a black border and diagonal stripes, reading: WARNING Hydraulic Tank Air Pressure Low. The bottom one is a red alarm box with a black border and diagonal stripes, reading: ALARM HYDRAULIC TANK AIR PRESSURE LOW. Both boxes have a status bar at the bottom with icons for 'Help', '01 Alarms', '00 Warnings', and '00 PIP Alarms', along with the date and time 'Mon 11/30/09 11:32:45 AM'.</p>	<p>Monitors:</p> <ul style="list-style-type: none"> • Hydraulic Tank Air Pressure – after the engine has been running for more than 10 minutes. <p>Yellow Alarm:</p> <ul style="list-style-type: none"> • If the hydraulic tank air pressure drops below 3 psi for more than 45 seconds then LINCS will generate a yellow alarm. <p>Red Alarm:</p> <ul style="list-style-type: none"> • If the hydraulic tank air pressure drops below 3 psi for more than 3 minutes then LINCS will generate a red alarm. <p>Action:</p> <ul style="list-style-type: none"> • Repair leak in the Hydraulic tank • Replace transducer • Replace Turck cables • Replace remote • Refer to troubleshooting sequence for detailed steps on finding the source of the leak

 <p>WARNING System Air Pressure Low</p> <p>1 Home 2 Help 00 Alarms 01 Warnings 00 PM Alerts Mon 11/30/09 11:32:43 AM</p>	<p>Monitors:</p> <ul style="list-style-type: none"> Distribution tank Air Pressure <p>Alarm:</p> <ul style="list-style-type: none"> If the distribution tank air pressure drops below 110 psi for .1 second (large brake canister) or below 80 psi for .1 seconds (small canister) then LINCS will generate an alarm. This is done to advise that the pressure is close to the point where the parking brakes will automatically apply <p>Action:</p> <ul style="list-style-type: none"> Repair system air leaks Refer to troubleshooting sequence for detailed steps on finding the source of the leak
 <p>WARNING Park Brake Pressure (Front/Rear) Sensor/Cable Fail</p> <p>1 Home 2 Help 00 Alarms 01 Warnings 00 PM Alerts Mon 11/30/09 11:32:43 AM</p>	<p>Monitors:</p> <ul style="list-style-type: none"> current from the 4-20 ma transducer on front and rear park brakes <p>Alarm:</p> <ul style="list-style-type: none"> If the current is below 2 ma (approx -25 psi) or above 22 ma (approx 243 psi) an alarm will be generated <p>Action:</p> <ul style="list-style-type: none"> Replace transducer Replace Turck cable Replace Turck box cable Replace remote
 <p>WARNING Service Brake Pressure (Front/Rear) Sensor/Cable Fail</p> <p>1 Home 2 Help 00 Alarms 01 Warnings 00 PM Alerts Mon 11/30/09 11:32:43 AM</p>	<p>Monitors:</p> <ul style="list-style-type: none"> current from the 4-20 ma transducer on front and rear service brakes <p>Alarm:</p> <ul style="list-style-type: none"> If the current is below 2 ma (approx -25 psi) or above 22 ma (approx 243 psi) an alarm will be generated <p>Action:</p> <ul style="list-style-type: none"> Replace transducer Replace Turck cable Replace Turck box cable Replace remote
 <p>WARNING KLENZ System Restriction High</p> <p>1 Home 2 Help 00 Alarms 01 Warnings 00 PM Alerts Mon 11/30/09 11:32:43 AM</p>  <p>ALARM KLENZ System High Restriction</p> <p>1 Home 2 Help 01 Alarms 00 Warnings 00 PM Alerts Mon 11/30/09 11:32:43 AM</p>	<p>Monitors:</p> <ul style="list-style-type: none"> KLENZ System Restriction <p>Yellow Warning:</p> <ul style="list-style-type: none"> If the KLENZ filter restriction is over 10" H2O for more than one minute then LINCS will generate a yellow alarm. <p>Red Alarm:</p> <ul style="list-style-type: none"> If the KLENZ filter restriction is over 12" H2O for more than 10 seconds then LINCS will generate a red alarm. <p>Action:</p> <ul style="list-style-type: none"> Replace KLENZ air filters Verify that the diaphragm valves are working properly Verify that LINCS is firing the diaphragm valves on the proper interval Repair air inlet damage or restriction Check the wiring to the sensor Replace the remote



 <p>NOTE: This alarm could also be generated for the e-stop switches on:</p> <ul style="list-style-type: none"> • Cab • Electrical Cabinet • Right Battery Box • Left Battery Box 	<p>Monitors:</p> <ul style="list-style-type: none"> • Voltage at the E-stop switch <p>Alarm:</p> <ul style="list-style-type: none"> • If the voltage is greater than 5V for more than .05 seconds then LINCS will generate a red alarm • Among other functions - this will cause the Dump valve to open and release air from the hydraulic tank. <p>Action:</p> <ul style="list-style-type: none"> • Reset the E-stop switch that was tripped • Close the Hydraulic Tank Air Pressure Dump valve • Replace the E-stop switch • Repair the wiring • Replace the remote
	<p>Monitors:</p> <ul style="list-style-type: none"> • Voltage at the KLENZ power switch <p>Alarm:</p> <ul style="list-style-type: none"> • If the engine is running and the voltage at the switch is less than 5V for more than .05 seconds then LINCS will generate a yellow warning message <p>Action:</p> <ul style="list-style-type: none"> • Turn the switch on • Replace the switch • Repair the wiring • Replace the remote

HYDRAULIC TANK AIR ADJUSTMENT

To correctly set the air pre-charge pressure of the hydraulic tank:

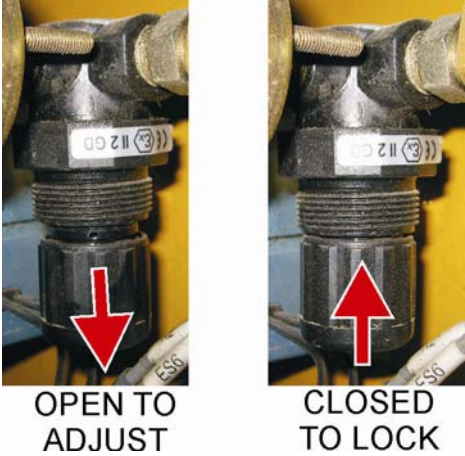
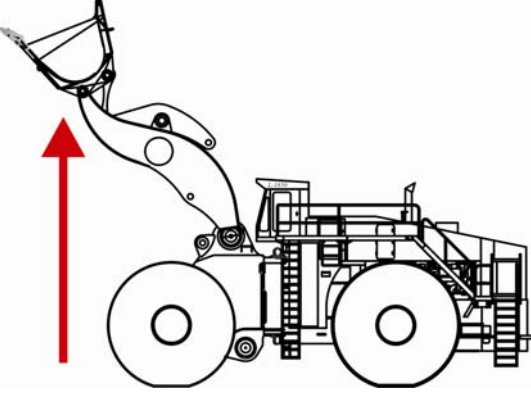
<p>1.</p>	<p>With the bucket set flat and level on the ground, check the oil level in the hydraulic tank.</p> <p>The level should be approximately 2" inches above the center of the sight glass.</p> <p>If the oil level is too high, nuisance hydraulic tank air pressure alarms will occur.</p>	
<p>2.</p>	<p>Remove the air from the hydraulic tank by opening the air supply cutoff and Automatic Hydraulic Tank Air Pressure dump valve.</p> <p>Air supply cutoff: Handle down vents the air.</p> <p>Automatic Hydraulic Tank Air Pressure dump valve: Black button pulled out.</p> <p>Leave open until all air has emptied from the hydraulic tank.</p>	
<p>3.</p>	<p>When all air is removed, close the air supply cutoff and air release valve.</p> <p>Air supply cutoff: handle up closes the vent and air goes into the tank</p> <p>Hydraulic Tank Air Pressure dump valve: The black button should be pushed all the way towards the valve.</p>	

<p>4.</p>	<p>Adjust the regulator looking at the attached gauge to 6 to 7 PSI.</p> <ul style="list-style-type: none"> • Pull the end cap on the regulator adjustment down firmly to unlock the regulator for adjustment. <p>NOTE: the end cap may be either black or yellow colored.</p> <ul style="list-style-type: none"> • Rotate the cap clockwise to increase, counter-clockwise to decrease. • Turn the cap slightly and allow the pressure to stabilize. • Once desire pressure is maintained, push the adjustor cap upward to lock. 	 
<p>5.</p>	<p>Stabilize the air pressure: After setting the air regulator the first time - raise the lift arms and leave them in the UP position for two (2) minutes to allow air to fill the larger area of tank exposed as oil level was reduced to fill the hoist cylinders</p>	

6	<p>After the lift arms are lowered back down, the 12 psi relief needs to be checked for proper operation. The air should only increase from 6 psi to about 9 psi if the regulator is set properly</p> <p>Air should not escape out of the relief after the lift arms are lowered.</p> <p>However, a continual release of air would indicate improper operation of the valve or that the air pressure regulator is not set or functioning correctly.</p>	
7.	<p>After the lift arms are lowered back down, the 14 psi relief on the top of the surge tank needs to be check for proper operation. Air should not escape out of the relief as the lift arms are lowered. A continual release of air would indicate improper operation of the valve.</p>	

If the pressure cannot be set, the following items need to be inspected and repaired and / or replaced.

- Main air system pressure is between 125 and 140 psi
- Solenoid #15 (air supply to the air pressure regulator) is operating properly
- Hydraulic Tank air pressure regulator is operating properly
- 12 psi check valve operating properly
- Automatic dump valve is closed
- 14 psi relief is operating properly
- Emergency stop button (s) are not pressed (automatic air dump valve will not reset to closed position)
- Fill Cap seal
- Hydraulic oil level is correct

Page left blank for double sided printing

Troubleshooting procedure to isolate a difficult to find air leak

System Air Pressure Low (Previously verified that this is not a LINCS problem such as cable or transducer)

How to use the troubleshooting table:

1. Answer the question in the initial step
2. If the answer is YES – go to the step indicated in the YES column
3. If the answer is NO – go to the step indicated in the NO column

SYSTEM AIR PRESSURE LOW – Troubleshooting procedure			
STEP	QUESTIONS	YES	NO
3	The Air System has a pressure of <100Psi. LINCS components have been verified as working properly.	4	Possible Causes
4	Ensure that all air tank drain valves are closed and KLENZ power switch is turned off and that KLENZ is not firing. Does the warning only occur when the service brakes are applied?	28	23
5	Kill the engine then release park brake. Allow System Air Pressure to stabilize for 30 seconds. Examine the following channels in LINCS: System Air Pressure, Front PB Pressure, Rear PB Pressure, KLENZ Pressure. Do you see a pressure drop of 1 PSI per minute or more on any channel?	6	Inspect the Inlet and Outlet lines of the Compressor for damage or restrictions. If none are present, replace the compressor.
6	Does the pressure drop occur only on the System Air Pressure channel?	10	7
7	Does the pressure drop occur on both the System Air Pressure and the KLENZ Air Pressure channels?	16	8
8	Does the pressure drop occur on both the System Air Pressure and the Front PB Pressure channels?	22	9
9	Does the pressure drop occur on both the System Air Pressure and the Rear PB Pressure channels?	24	5
10	Kill the engine and bleed system air pressure to 0 PSI. Remove the tee fitting feeding the miscellaneous air system components and plug the tank [X size fitting]. Restart the Engine or use shop air to pressurize the system to full pressure. Does the System Air Pressure channel continue to report dropping air pressure?	15	11

SYSTEM AIR PRESSURE LOW – Troubleshooting procedure			
STEP	QUESTIONS	YES	NO
11	Kill the engine and bleed system air pressure to 0 PSI. Reinstall the tee fitting feeding the miscellaneous air system components and plug all but one of the tee'd component lines [X size fitting]. Restart the Engine or use shop air to pressurize the system to full pressure. Does the System Air Pressure channel report dropping air pressure now?	12	13
12	The leak is most likely the circuit that has been added. Kill the engine and bleed system air pressure to 0 PSI. Trace the circuit to the component, remove the component and cap or plug the component. Restart the Engine or use shop air to pressurize the system to full pressure. Does the System Air Pressure channel to report dropping air pressure now?	Replace the hose between the distribution tank and component.	Replace the component.
13	Kill the engine and bleed system air pressure to 0 PSI. Remove the plug for the next component and connect the component line to the tee. Restart the Engine or use shop air to pressurize the system to full pressure. Does the System Air Pressure channel report dropping air pressure now?	12	14
14	Kill the engine and bleed system air pressure to 0 PSI. Remove the plug for the last component and connect the component line to the tee. Restart the Engine or use shop air to pressurize the system to full pressure. Does the System Air Pressure channel report dropping air pressure now?	12	The problem was most likely a loose fitting that has been tightened during the course of troubleshooting. If you are unsure of the solution repeat the process.
15	With the engine NOT running and the Distribution Tank fully charged, inspect the output of the Air Dryer. Is air escaping from the purge port of the dryer?	Replace the check valve located on the output of the Air Dryer.	25
16	The regulator feeding the hydraulic tank should be set to 6 PSI. Is this true?	17	Adjust to 6 PSI and recheck.
17	Kill the engine and bleed system air pressure to 0 PSI. At the KLENZ tank, plug the line supplying air to the hydraulic tank circuit. Restart the Engine or use shop air to pressurize the system to full pressure. Does the KLENZ Air Pressure channel still report dropping air pressure?	21	18

SYSTEM AIR PRESSURE LOW – Troubleshooting procedure			
STEP	QUESTIONS	YES	NO
18	Close the ball valve located on top of the Hydraulic Tank. Does the KLENZ Air Pressure channel still report dropping air pressure?	19	Use ultrasonic leak detector. Leak is isolated to the Hydraulic Tank and related components. Check the following: Cap, Dump Valve, Filler Cap, etc.
19	Is the 12 PSI check valve leaking?	Replace Check Valve	20
20	Use soap and water or ultrasonic leak detector. Is the Hydraulic Tank Supply solenoid leaking?	Repair or Replace Solenoid	Problem exists in hose between KLENZ tank and regulator. Repair or replace hose/fitting.
21	Kill the engine and bleed system air pressure to 0 PSI. At the KLENZ tank, plug the leaving the solenoid going to the KLENZ box. Restart the Engine or use shop air to pressurize the system to full pressure. Does the KLENZ Air Pressure channel still report dropping air pressure?	There is a leak in the KLENZ tank system. Inspect the regulator, solenoid valve, and the tank and associated fittings. Repair this leak and recheck.	Use ultrasonic leak detector. Leak is isolated to the KLENZ Box and related components. Check the following: Pulse Solenoid, Pulse Valves, Diaphragms, Lines. etc.
22	With the Park Brakes released, is the Front Park Brake Relay Valve leaking air from the exhaust port?	Repair or Replace the Front Park Brake Relay Valve.	Check for Leaks in the hoses between PB Relay Valve and the Brake Canister.
23	The governor setting should be 135 PSI. When 135 PSI is reached the governor shifts the purge valve in the dryer and unloads the outlet of the compressor. In LINCS browse the System Air Pressure channel. Does the System Air Pressure build to 135 PSI and then stabilize?	5	30
24	With the Park Brakes released, is the Rear Park Brake Relay Valve leaking air from the exhaust port?	Repair or Replace the Rear Park Brake Relay Valve.	Check for Leaks in the hoses between PB Relay Valve and the Brake Canister.

SYSTEM AIR PRESSURE LOW – Troubleshooting procedure			
STEP	QUESTIONS	YES	NO
25	Kill the engine and bleed system air pressure to 0 PSI. Remove the line feeding the Front Brake tank and plug the Distribution tank [X size fitting]. Restart the Engine or use shop air to pressurize the system to full pressure. Does the System Air Pressure channel continue to report dropping air pressure?	26	Replace the hose from the Distribution Tank and the Front Brake Tank.
26	Kill the engine and bleed system air pressure to 0 PSI. Remove the line feeding the Rear Brake tank and plug the Distribution tank [X size fitting]. Restart the Engine or use shop air to pressurize the system to full pressure. Does the System Air Pressure channel continue to report dropping air pressure?	27	Replace the hose from the Distribution Tank and the Rear Brake Tank.
27	Kill the engine and bleed system air pressure to 0 PSI. Remove the line feeding the KLENZ tank and plug the Distribution tank [X size fitting]. Restart the Engine or use shop air to pressurize the system to full pressure. Does the System Air Pressure channel continue to report dropping air pressure?	The problem is either the tank or the tank safety relief valve. Use soap and water to detect leaks.	Replace the hose from the Distribution Tank and the inlet of the KLENZ Pressure Regulator.
28	Charge the air system to 135 PSI [engine running or shop air if this air pressure level is available]. Examine the following channels in LINCS: System Air Pressure, Front Service Brake Pressure, and Rear Service Brake Pressure. Apply the service brake pedal and hold constant, do you see a decline in Front Service Brake Pressure?	There is a leak in the Front Service Brake system. In the front axle, inspect the Service Brake Relay Valve and Canisters. Under the Cab inspect the Treadle Valve. Repair this leak and recheck.	29
29	Follow same procedures as in the previous step. Do you see a decline in Rear Service Brake Pressure?	There is a leak in the Rear Service Brake system. In the rear axle, inspect the Service Brake Relay Valve and Canisters. Under the Cab inspect the Treadle Valve. Repair this leak and recheck.	Please restart the test procedure, some element may have been missed.
30	Are you able to adjust the governor to achieve 135 PSI?	Done	31

SYSTEM AIR PRESSURE LOW – Troubleshooting procedure			
STEP	QUESTIONS	YES	NO
31	Remove and replace the governor. Does this fix the problem?	Done	5
32	Use LINCS to inspect the channels for System Air Pressure, Front and Rear Park Brake pressure. With the park brakes released are the reported air pressures relatively equal [$\pm 10\%$]?	6	33
33	Remove and replace the transducer for the channel that was not equal to the others [System Air Pressure, Front and Rear Park Brake Pressure]. Does this fix the problem?	Done	There is a problem with the Remote Module signal processing. Replace the Remote Module.

REVISION HISTORY			
Revision	Description	Created/ Modified By	Date
.01	Corrected graphic on page 7	Randy plants	11/25/08
.00	Original Release	Randy Plants	8/06/08